



DS200

Operator Guide

Document Version 10.1

Hardware Version 1.2

Firmware Version 2.7

February 7, 2013

Election Systems and Software, LLC.
Corporate Headquarters
11208 John Galt Blvd.
Omaha, Nebraska 68137
United States of America
Phone: (402) 593-0101
Toll Free Inside of U.S.: (877) 377-8683
Fax: (402) 593-8107
<http://www.essvote.com>
Copyright © 2013 All Rights Reserved

© 2012 by Election Systems & Software, 11208 John Galt Blvd., Omaha, NE 68137-2364.
 All rights reserved. Printed in the USA
 DS200 Operator Guide

This document, as well as the product described in it, is furnished under license and may be used or copied only in accordance with the terms of such license. The content of this document is furnished for informational use only, is subject to change without notice, and should not be construed as a commitment by Election Systems & Software, LLC (ES&S). Election Systems & Software, LLC, assumes no responsibility or liability for any errors or inaccuracies that may appear in this document. Except as permitted by such license, no part of this publication may be reproduced, stored in a retrieval system, or transmitted, in any form or by any means, electronic, mechanical, recording, or otherwise, without the prior written permission of Election Systems & Software, LLC.

Disclaimer

Election Systems & Software does not extend any warranties by this document. All product information and material disclosure contained in this document is furnished subject to the terms and conditions of a purchase or lease agreement. The only warranties made by Election Systems & Software are contained in such agreements. Users should ensure that the use of this equipment complies with all legal or other obligations of their governmental jurisdictions.

All products described in this document are registered trademarks of Election Systems & Software, LLC. All other products mentioned are the sole property of their respective manufacturers.

Proprietary Information

ES&S has identified and appropriately marked relevant portions of this document, which it considers confidential and proprietary. We request confidential treatment by the EAC of such information and would expect that such information is exempt from required disclosure. In the event that a third party requests disclosure of information which ES&S considers confidential and proprietary, we would ask that the EAC notify ES&S of such requested disclosure in order to provide us with an opportunity to seek exemption from disclosure.

The document sections referenced below contain Election Systems and Software, LLC. (ES&S) confidential information, which is provided for the sole purpose of permitting the recipient, to evaluate the ES&S Voting System submitted herewith. The following sections are designated as "Proprietary and Confidential" by Election Systems & Software.

Proprietary Document Section	Description
N/A	N/A

Table of Contents

Disclaimer	2
Proprietary Information	2
Introduction	1
Chapter 1: Overview	2
Jurisdictional Nomenclature	2
Contact ES&S for Technical Support.....	2
Contact ES&S For Ordering Information.....	3
General Timeline for Election Preparation	3
Facilities, Furnishings and Fixtures Required for DS200 Operation	4
Specifications and Cautions.....	5
System Acquisition Procedures	6
Visual Inspection:	6
Physical Inspection:	6
Roles	8
Chapter 2: Safety Information.....	9
Warning Symbols.....	9
Important Safety Instructions	9
Power Sources	9
Ventilation	10
Water and Moisture	10
Cleaning	10
Heating	10
Power Cord Protection	10
Radiation Protection.....	10
Servicing	11
Damage Requiring Service.....	11
Battery Replacement Warning	11
Chapter 3: Introduction to the DS200.....	12
Power Source and Backup Battery	12
Ballot Box.....	14
Scanning Ballots.....	15
USB Flash Drive.....	16
Touch Screen Controls.....	16
Menu Display	17
Operating Modes.....	18
Administration Mode	18
Polls Open Mode	18
Polls Closed Mode	19
Election Definition	19

Election Security	19
Using the DS200 in an Election	25
Chapter 4: Pre-Election Day Tasks	26
Recommended Supplies	26
Attach the DS200 to the Ballot Box	27
Assemble the Plastic Ballot Box	27
Attach the DS200 Power Source to the Plastic Ballot Box	28
Attach the DS200 to the Plastic Ballot Box	35
Seals and Locks	37
DS200 Seals and Locks	37
DS200 Carrying Case and Ballot Bin Security Seals	38
Steel Ballot Box	39
Attach the DS200 to the Metal Ballot Box	40
Tote Bin (optional)	42
Preparing the DS200 Ballot Box to receive the Tote Bin	42
Inserting the DS200 Tote Bin into the Plastic Ballot Box	43
Prepare the Counter	44
Loading New Firmware	45
Charge the Battery	47
USB Backup Memory Device	48
Install the Backup Memory Device	48
DS200 Backup Media Device Set-up	49
Clear the DS200	49
Load the Election Definition	51
Check the Election Definition for Accuracy	54
Administration Menu	54
Ballot Diagnostics	57
Scan Ballot	57
Reports	57
Hardware Diagnostics	58
Hardware Reports	58
System Settings	60
Change Date and Time Settings	60
Change the Time	63
Change The Time Zone	64
Save Your Time Settings	65
Hardware Settings	65
Top CIS Threshold & Bottom CIS Threshold	65
Calibrate Scanner	66
Calibrate the Touch Screen	66
Test the Thermal Printer	68
Pre-Voting Checklist	69
Optional Step: Configuring the DS200 to Not Require a Security Code to Enter Voting Mode	69

Optional Step: Create Media to Validate Firmware	71
Chapter 5: Election Day Tasks	73
Open the Polls	73
Report Options	76
Voting	77
Overvoting Warnings.....	78
Undervoting Warnings	79
Overvote and Undervote Warnings.....	80
Blank Ballots	84
Multi-Language Voting	85
Write-in Votes	87
Assist ADA Voters	88
Precinct Selection During an Early Voting Period.....	88
Using the Tools Menu.....	89
Override Ballot Rejection	90
Report Options	91
Handling Uncounted Ballots.....	91
Metal Ballot Box	92
Plastic Ballot Box	92
Close the Polls	93
Emergency Procedure to Shutdown the DS200	95
Reopen the Polls Without Clearing Vote Totals	95
Reopen the Poll and Clear Vote Totals	97
Closing and Removing the DS200 Tote Bin from the Plastic Ballot Box	101
Remove Ballots from the Metal Ballot Box	104
Print Election Reports.....	104
Transfer Results.....	105
Chapter 6: Post Election Day Tasks.....	106
Remove the Scanner From the Ballot Box.....	106
DS200 Lower Ballot Bin Storage	110
DS200 Reports and Maintenance	111
Chapter 7: Reports	112
Report Format	112
Election Startup Reports.....	112
Ballot Status Accounting Report.....	113
Zero Totals	116
Event Log Report	117
Configuration Report.....	118
Poll Closing Report	119
Results Report	120
Chapter 8: Scanner Maintenance	122

Clean the Scanner.....	122
Clean the Ballot Box	124
Clean the Plastic Ballot Box	124
Clean the Metal Ballot Box	125
Replace the Paper Roll.....	125
Replace the Write-in Stamp	126
Maintain the Scanner Battery	128
Battery Cautions	129
Charge the Battery	129
Preventative Maintenance During High Volume Accuracy Testing.....	129
Appendix	131
Chapter 9: DS200 Quick Start Guide	132
Attach the DS200 to the Plastic Ballot Box.....	132
Attach the DS200 to a Metal Ballot Box	134
Seals and Locks	137
DS200 Seals and Locks.....	137
DS200 Carrying Case and Ballot Bin Security Seals.....	138
Steel Ballot Box.....	139
Open the Polls	140
Close the Polls	143
Chapter 10: Troubleshooting.....	145
Emergency Ballot Storage Bin	145
Recovering or Replacing the DS200.....	146
Calibrate the Touch Screen	147
Chapter 11: System Messages	153
System Error Recovery	153
Verification Messages	153
Numeric Messages	154
Chapter 12: Revision History	212

Part 1: Introduction

Part 1 contains information about the following topics.

- ❖ [Chapter 1: Overview](#)
- ❖ [Chapter 2: Safety Information](#)
- ❖ [Chapter 3: Introduction to the DS200](#)

Chapter 1: Overview

The DS200 precinct ballot scanner is part of a jurisdiction-wide election tabulating system. Voters insert their ballots directly into the DS200 at the polling place. The scanner tabulates votes and feeds inserted ballots into an attached ballot storage bin.

Election law and procedures vary from jurisdiction to jurisdiction. Use the procedures in this manual in conjunction with the election policies and guidelines for your jurisdiction to develop a comprehensive election strategy.

Jurisdictional Nomenclature

Terminology for the lowest-level common geopolitical civil division differs by state and country. In this manual and other ES&S documentation, the entity is referred to as a precinct.

As a company with accounts across the country and around the world, ES&S recognizes that certain jurisdictions use terms other than precinct. Some examples of the terms used by other jurisdictions are Election District (or ED), Borough, Province, Division, and District. These terms and others may be substituted for precinct depending upon the particular jurisdiction. However, for consistency, ES&S uses the term precinct throughout its documentation.

Contact ES&S for Technical Support

The *DS200 System Operations Procedures* contains comprehensive instructions for using the tabulator and descriptions of all scanner functions. If you require additional assistance or encounter a processing problem or system error, contact the ES&S technical support staff for advice or assistance.

Stay close to your scanner when you contact ES&S for support. Also, be prepared to provide the following information to the ES&S support representative:

1. The model number of your tabulator.
2. The version number of the firmware installed on the tabulator.
3. The exact wording of any messages displayed by the scanner.
4. A description of what happened to cause the problem.

Support representatives normally answer calls Monday through Friday between 8:00 A.M. and 5:00 P.M. central time.

Contact an ES&S Support Representative

Telephone:	877-377-8683 (USA & Canada) 402-593-0101 (International)
Fax:	402-593-8107
Write:	Election Systems & Software 11208 John Galt Blvd Omaha, NE 68137 USA

ES&S support services are subject to the prices, terms, and conditions in place at the time the service is used.

Contact ES&S For Ordering Information

To obtain additional DS200 units, USB flash drives, test deck ballots or other products, call ES&S at 877-377-8683.

General Timeline for Election Preparation

90 Days	Submit site support request to ES&S
63 Days	All forms are due to ES&S (excluding Candidate forms)
56 Days	Candidate forms due to ES&S
46 Days	Last day to give ballot proofs to Counties (strictly for military or overseas voting).
45 Days	Absentee Voting begins
42 Days	Certification Deadline
28 Days	All ballot proofs must be signed off
21 Days	Last day to deliver Election Day ballots
20 Days	Advance or early voting begins
18 Days	Last day for ES&S to ship coding materials
10 Days	Software Installation for pre-election procedures
1 Day	Early voting ends



Reference: Refer to the Personnel Deployment and Training Requirements document for more detailed information.

Facilities, Furnishings and Fixtures Required for DS200 Operation

The DS200 is a precinct count tabulator. The weight of the DS200 is about 25 pounds. The weight of the carrying case is about 10 pounds. The weight of the plastic ballot box is 37 pounds. The weight of the metal ballot box without a ballot diverter is 103 pounds. The weight of the metal ballot box with a diverter is 107 pounds.

- ❖ At the polling place, the DS200 should be placed on top of its ballot box. Leave a minimum of 36 inches to each side of the DS200 for wheelchair accessibility.



Warning: Do not transport the DS200 while attached to the metal ballot box. The DS200 should be delivered separately in the tabulator's storage and transport case and attached to the metal ballot box at the polling location.

- ❖ A standard 110V outlet must exist in the facility for power cord plug in. The DS200's input rating is 120V~50/60 Hz 2A. The main supply voltage fluctuations are not to exceed plus or minus 10 percent of the rated supply voltage area. It is recommended that the unit is plugged directly into a power supply without the use of an extension cord.
- ❖ The DS200 is intended for indoor use only.
- ❖ Operational humidity during operations should be between 10 - 50 percent RH.









Warning: Do not place containers with liquids such as coffee, water or soda on or near the DS200. Do not operate the scanner in an excessively wet environment. Store the DS200 in a cool dry place. The DS200 is not protected against harmful ingress of moisture.



- ❖ The DS200 needs to be stored and operated in a Pollution Degree 2 environment.

Specifications and Cautions

Specifications and Cautions

	Indoor Use Only
	Ordinary Protection (not protected against harmful ingress of moisture)
	At the polling place, the DS200 should be placed on top of its ballot box. Leave a minimum of 36 inches to each side of the DS200 for wheelchair accessibility.
	Weight: The weight of the DS200 is about 25 pounds. The weight of the carrying case is about 10 pounds. The weight of the plastic ballot box is 37 pounds. The weight of the metal ballot box without a ballot diverter is 103 pounds. The weight of the metal ballot box with a diverter is 107 pounds.
	Electrical input rating: A standard 110V outlet must exist in the facility for power cord plug in. The DS200's input rating is 120V~50/60 Hz 2A. The main supply voltage fluctuations are not to exceed plus or minus 10 percent of the rated supply voltage area. It is recommended that the unit is plugged directly into a power supply without the use of an extension cord. Consult a licensed electrical contractor for proper electrical connections.
	Pollution Degree 2 for the ambient environment
	Operating relative humidity: 10% to 50% Relative Humidity Storage relative humidity: 10% to 85% Relative Humidity
	Operating temperature: +60 to +100 degrees Fahrenheit Storage temperature: 0 to +120 degrees Fahrenheit

Specifications and Cautions

	<p>Maintenance: For applicable maintenance items, refer to the <i>DS200 System Maintenance Manual</i>.</p>
	<p>Caution: The interior of the DS200 is not accessible to the user. Service operations inside the electrical enclosure must be done by trained and authorized personnel.</p>
	<p>DS200 Dimensions:</p> <ul style="list-style-type: none"> ❖ Stored configuration <ul style="list-style-type: none"> • Width - 14 inches • Depth - 16 inches • Height - 5 inches ❖ Operation state with screen deployed <ul style="list-style-type: none"> • Width - 14 inches • Depth - 16 inches • Height - 13.5 inches

System Acquisition Procedures

The following is a recommended list of the DS200 Acceptance Testing Criteria.

Visual Inspection:

- ❖ Ensure that there are no scratches or gouges on any part of the unit
- ❖ Verify that all labels are placed in their appropriate place and in their correct orientation
- ❖ Ensure the Printer paper roll is installed in the Printer.

Physical Inspection:

- ❖ Apply AC to Wall Power Adapter. Connect Wall Power Adapter to the back of the unit and press the “POWER” button.
- ❖ Observe the rear LED, located next to the Wall Power Adapter Cord Connector, if the LED is amber and blinking slowly this indicates that the Battery Pack is charging. If the LED is a solid green, the Battery Pack is completely charged.

- ❖ Verify AC Plug Icon is present and the indicator shows a light blue and dark blue plugged together in the right corner of the screen.
- ❖ Verify the DS200 Firmware, PMB and Scanner version on the Configuration Report.
- ❖ Insert the USB Flash Drive containing the Election Qualification Code (EQC) with a demo or specific election into the USB port inside the access door
- ❖ When prompted remove the EQC flash drive and insert a USB Flash Drive containing the election definition into the USB port inside the access door.
 - When the unit recognizes the USB Flash Drive containing the election definition, the Election Icon will go from having an “X” to a green ? mark on it.
- ❖ Access the Administration Menu to not only calibrate the scanner touch screen but complete other set up tasks also.
- ❖ Once you load the election definition, the scanner touch screen may need to be calibrated.
 - Press the Admin Icon in the upper-right hand area of the screen.
 - Press **Log In** and enter the Election password on the touch screen then press **Accept**.
 - From the Administrative Menu on the left hand side of the screen, choose **System Settings**.
 - Press **Calibrate Touch Screen** then **Continue** to begin the process.
 - Touch the two circles (one in the Upper Left Corner and one in the Lower Right Corner of the screen) and then touch the **Save & Exit** button.
- ❖ Check the date and time on the top portion of the display to ensure the date and time is correct.
 - If a change is needed, select **System Settings** then press **Date and Time Options**. Once you have completed any changes select **Logout** and then **Exit**. Select from the following options:
 - **Change Date:** select the current date from the calender, the press **Apply** to save the changes.
 - **Change Time:** use the up and down arrows to select the current time. Press **Apply** when completed
 - **Change Time Zone:** use the up and down arrows to locate the correct time zone. When you have selected the correct time zone press **Apply**.
- ❖ Press the “OPEN POLLS” button on the screen to scan the test ballots.
- ❖ Ensure that the test ballots scan in all four orientations.
- ❖ Insert the two ballots to check the Multi-Sheet Sensor. Both sheets should be rejected.
- ❖ Press and hold the “CLOSE POLL” button for two seconds to close the polls.
- ❖ Verify that the Results Report shows four ballots cast.

- ❖ Disconnect the Wall Power Adapter cord from unit.
 - Unit should continue to operate, and the a battery icon should appear over the AC icon.
 - ❖ Re-connect Wall Power Supply cord
 - The battery icon should disappear from the AC icon.
 - ❖ Power down the unit by touching the “Finished-Turn Off” button on the Touch Screen.
 - ❖ Verify that the Display switch operates correctly by completing the following:
 - With the Wall Power Adapter still connected to the unit, lower the Display to the closed position.
 - Raise the Display back to the opened position.
 - The unit should power back up.
-  **Note:** The Display switch will not operate if the Wall Power Supply cord has been removed.
- ❖ Verify all Locks and Doors have a smooth function and are locked.

Roles

Election officials prepare the ballots and the election database to be used by the DS200.

Election officials and/or polling place staff unpack and install the system, conduct the verification test to determine the operational integrity, and are responsible for system shut down, maintenance, and packing. At the polling place, election officials setup the system hardware and perform the following operations:

- ❖ System Startup/Shutdown
- ❖ System Installation and Test

Polling place staff (Poll Workers) also assist voters with gaining familiarity with the system, clearing paper jams, etc.

Voters use the DS200 to tabulate their ballots.

Chapter 2: Safety Information

This chapter contains information that will help keep you safe while operating the DS200.

Warning Symbols

The following symbols appear in the *DS200 System Operations Procedures* next to the descriptions for any procedure that, if improperly executed, could cause harm to the operator or damage to the scanner. Read all of the instructions in this manual and use extra caution when you carry out any task that may pose a physical danger to yourself or the DS200 tabulator.



Electrical Shock Danger: This symbol appears next to procedures that expose the operator to a risk of electric shock. Any operation that requires opening the DS200 enclosure exposes users to dangerous high voltages. To reduce the risk of fire or shock, do not attempt to open the DS200 enclosure unless you receive proper training from an ES&S technician.



Warning: The user warning symbol appears next to procedures that could cause damage to the scanner or injury to the operator if improperly executed. Carefully read all warnings and proceed with caution if you choose to carry out these tasks.

Important Safety Instructions



Read and follow the safety recommendations in this section of the *DS200 System Operations Procedures* to maintain proper safety measures when operating the scanner.

Power Sources

Only use the type of power source indicated on the ID label of your DS200 to power the tabulator. Make sure that you install the tabulator in compliance with all applicable sections of the National Electric Code. Consult your local building code before you install any ballot-scanning equipment.

Ventilation

The case of the DS200 scanner contains slots and openings that provide the ventilation for the unit. To prevent the DS200 from overheating, do not block or cover any of the scanner's openings during operation. Do not operate the DS200 in an enclosed housing unless ES&S approves the container. Use only the integrated ballot box supplied by ES&S as a ballot container for the DS200.

Water and Moisture



Warning: Do not place containers with liquids such as coffee, water or soda on or near a DS200 terminal. Do not operate the scanner in an excessively wet environment. Store the DS200 in a cool dry place.

Cleaning

Follow instructions in the [Clean the Scanner](#) heading of Chapter 9 to properly maintain the DS200. Use only the cleaning solutions approved and specified by ES&S to clean the tabulator and ballot box.

Heating

Do not install the DS200 near heat sources such as radiators, air ducts, areas subject to direct sunlight or other products that produce excessive heat.

Power Cord Protection

After you plug the scanner into an approved outlet, route or install the power cord for the DS200 in such a manner to protect it from people walking over the cord. Turn off the DS200 before connecting or disconnecting the power cord. Remove the power cord before you move the unit. Only plug the power cord in to an easily accessible unobstructed wall socket.

Radiation Protection

The DS200 fully complies with Federal Communications Commission regulations on protection against generated or induced electromagnetic radiation.

Servicing

Do not attempt to service the scanner unless specifically instructed to do so by ES&S. Do not attempt to open the scanner case or perform internal maintenance unless you receive proper training from ES&S.

Damage Requiring Service

Some situations require an ES&S technician to resolve. Unplug the DS200 and call ES&S to schedule service with a technician for the following conditions. Do not attempt to repair the scanner without first contacting ES&S.

- ❖ When the power cord is damaged
- ❖ If liquid is spilled into the scanner casing
- ❖ If the product is physically damaged in any way
- ❖ When the scanner displays a negative change in performance

Additionally, seek assistance from ES&S if the scanner does not function according to the descriptions in this manual. Unless you receive specialized training from ES&S, do not attempt to adjust advanced settings that are not described in the *DS200 System Operations Procedures* manual. Improper adjustment of advanced controls may result in damage to the scanner and often require service by an ES&S technician to restore the scanner.

Battery Replacement Warning



Electrical Shock Danger: Improperly replacing the terminal battery exposes the operator to a risk of explosion. Only qualified ES&S technicians should replace DS200 scanner batteries.

Chapter 3: Introduction to the DS200

Use the diagrams and descriptions in this chapter to familiarize yourself with DS200 scanner components and functions. Always scan a ballot test deck before your election to test the scanner for accuracy and to correct any functional errors before you count official ballots.



Reference: See [Chapter 4: Pre-Election Day Tasks](#) for a list of recommended polling place supplies and instructions for assembling and testing the DS200,

The DS200 scanner reads marks on both one- and two-sided ballots. Administrators can request custom ballot acceptance criteria, which ES&S programs onto the scanner's election definition. These ballot acceptance criteria are loaded on a USB flash drive. For example, if a jurisdiction prohibits counting blank ballots, ES&S election coders can program the DS200 to return blank ballots to the voter for review and/or changes.

The DS200 can generate paper reports produced from the scanner's internal thermal printer. The DS200 stores election results on a removable USB flash drive that you can use to transfer scanner results to Election Reporting Manager after the polls close.

Power Source and Backup Battery

An external DC power supply, which plugs into a standard 120-volt AC outlet, supplies power to the scanner. If a power outage occurs, the DS200 contains an internal back-up battery that can run the scanner for a minimum of two hours, depending on scanner activity. The following window appears if the DS200 is not plugged in.

The battery status indicator appears next to the time (see the red circle in the below graphic). A “Not plugged into electricity!” message appears if the machine is not connected to power.



If the DS200 is plugged into a power source, the backup battery will be charged.

A power indicator light, located at the back of the DS200, displays the backup battery status.



Power Indicator Light

- If the light is flashing **green**, the battery is fully charged and not plugged in.
- If the light is green and not flashing, the DS200 is plugged in and the battery is fully charged.
- If the light is flashing at a slow rate, the battery is 75 percent charged.
- If the light is flashing at a medium rate, the battery is 50 percent charged.
- If the light is flashing at a fast rate, the battery is 25 percent charged.

- ❖ If the light is **amber**, the battery is charging. If the light is amber, allow the DS200 to charge until the light turns green. If the battery is not charged, it will take up to six hours to charge the battery.
 - If the light is flashing at a slow rate, the battery is 75 percent charged.
 - If the light is flashing at a medium rate, the battery is 50 percent charged.
 - If the light is flashing at a fast rate, the battery is 25 percent charged.
- ❖ If the light is **flashing red**, the battery is not taking a charge. This could be caused by:
 - A dead battery.
 - A bad connection to the battery.
 - No battery is in the DS200.



Note: If the DS200 has not operated on battery power and was stored with a full battery charge, the charge time required to fully recharge the battery will be minimal.

Ballot Box

DS200 ballot boxes store ballots and hold the scanner at the polling place. The DS200 feeds scanned ballots directly into the ballot box, which can sort the ballots according to criteria programmed in the election definition with an optional internal diverter. When ballot sorting is necessary, use of the ES&S steel ballot box with diverter (Item # 76246) is required in lieu of the DS200 plastic ballot box. The ballot box also has a compartment that poll workers can use to temporarily store uncounted or contested ballots in the event of a power failure or scanner malfunction.



Scanning Ballots

The DS200 can scan ballots inserted in any direction or orientation. Depending on the options set for your election definition, the DS200 will use one of the following methods for accepting or rejecting blank ballots, overvotes and undervotes.

- ❖ **Unconditional acceptance:** The scanner accepts and tabulates results for all ballots. Any contests that are blank, overvoted or undervoted will be logged as such and the remaining contests will be tabulated appropriately.
- ❖ **Unconditional rejection:** The DS200 automatically rejects undervoted, overvoted or blank ballots. Voters must review and correct ballot selections before the scanner will accept the ballot.
- ❖ **Query the voter for correction:** The DS200 returns a questioned ballot to the voter and displays a screen message that describes the problem and prompts the voter to either review and edit the ballot or cast the ballot as it is. The voter presses **Don't Cast - Return Ballot** to correct the ballot or presses **Cast Ballot** to cast the ballot without editing selections. Once **ACCEPT** is pressed, the message **Thank you for voting. Your ballot has been counted.** appears.

Poll workers should closely monitor system messages during voting.



Reference: For descriptions of system messages and recommended actions, see [“Chapter 9: DS200 Quick Start Guide”](#)



If you encounter a problem that you cannot correct, contact election headquarters or ES&S technical support.

USB Flash Drive

The DS200 uses a USB flash drive to store the scanner’s election definition, audit log and other election-specific information. Data on the USB flash drive is updated each time the DS200 scans a ballot. Use USB flash drives with a memory capacity of 1 to 8 GB.



Warning: Ensure that DS200 USB memory devices are properly formatted to the FAT32 file system prior to loading devices with election configuration files.

Touch Screen Controls

The LCD touch screen provides access to all scanner function options. Press the buttons on the LCD screen to navigate the DS200 menu options. A security code is required to access administrative menu options.

Menu Display

The DS200 LCD display screen displays the available menu options. The top-center line of text on the screen identifies the current menu. The icons on the upper-right region of the window display the date, time and operating status of the DS200. The buttons on the current screen display the menu options.

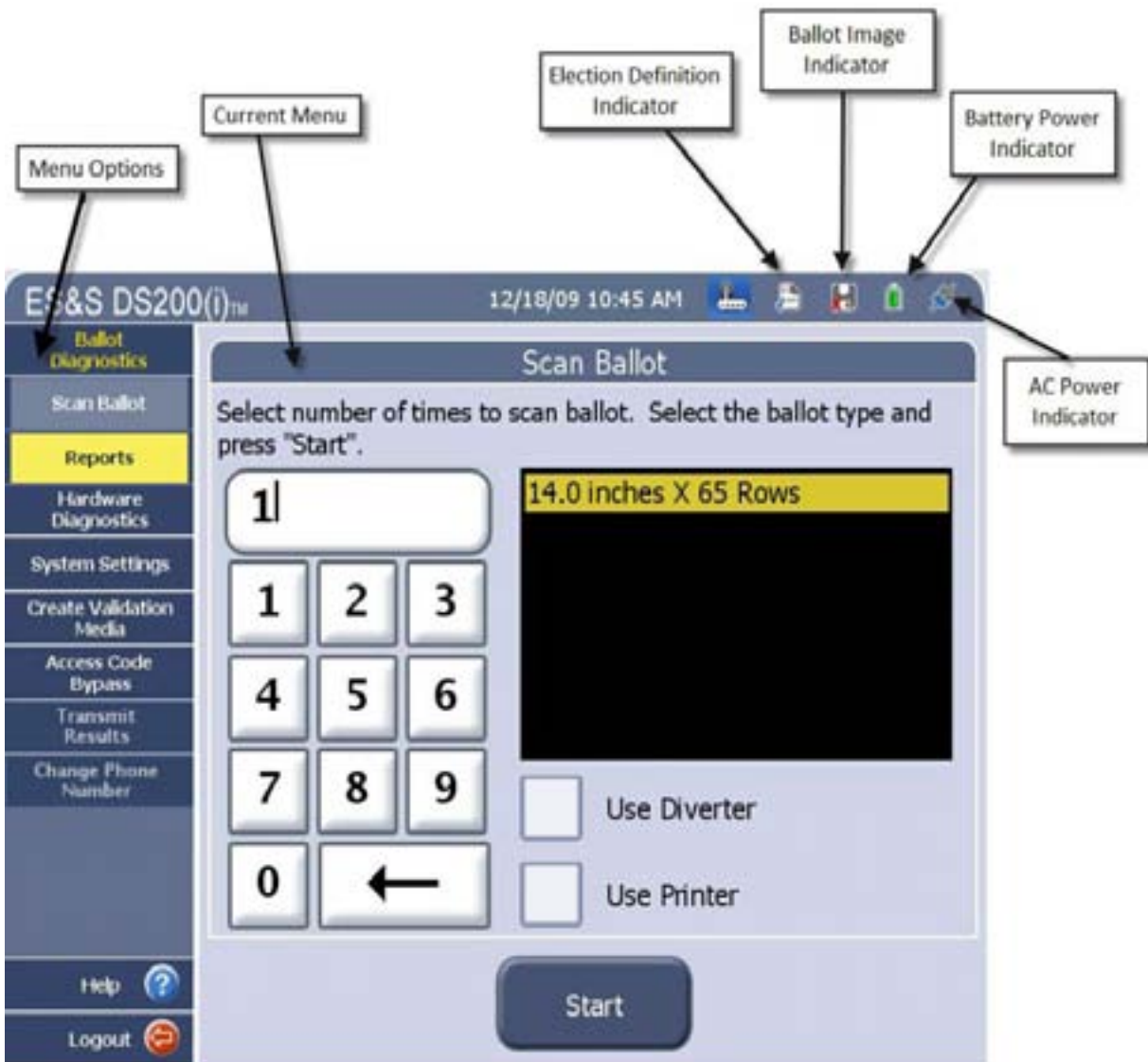

Operators with appropriate permissions can access most menu options through a series of sequential steps, while other options are only available while the polls are not open.



Reference: Refer to [Chapter 9: DS200 Quick Start Guide](#) for a list of menu commands and functions.

Operating Modes

The DS200 operates in three separate modes:

- ❖ Administration
- ❖ Polls Open
- ❖ Polls Close

The Administration Mode provides diagnostic and testing functions to calibrate and test the scanner. In polls open mode, the DS200 actively scans ballots and tabulates results. In polls closed mode, the scanner prints poll reports and transfers election results.

Administration Mode

Open the scanner in administration mode to calibrate the scanner, test your election definition and ballots, check the settings and scanner diagnostics.

Election officials should load system programs and test DS200 election definitions before delivering scanners to polling places. Complete the following tasks to prepare a scanner for an election:

1. Load the election definition into the scanner.



Reference: For more information, see the [Load the Election Definition](#) heading of Chapter 5.

2. Test the election definition and the scanner to ensure accuracy.



Reference: For more information on testing the scanner, see the [Prepare the Counter](#) section of Chapter 5.

Polls Open Mode

Open the polls to begin regular Election Day functions such as scanning ballots and tabulating vote totals.

Poll workers should monitor the scanner during an election, but the DS200 requires minimal poll worker involvement during voting. The poll worker's main responsibility during voting is responding to system messages.

Polls Closed Mode

Close the polls at the assigned time to print reports or transfer scanner totals to election headquarters. Available DS200 reports include Status Reports, Poll Reports, Precinct Reports, and the Audit Log report.

Election Definition

Election coders program a custom election definition onto a USB flash drive for each DS200 used in your jurisdiction. An election definition contains all of the candidates, contests and ballot variations that the scanner will process at the polling place. The election definition also contains customizable program options that control how the tabulator operates and reports results. Customizable options include (but are not limited to):

- ❖ Ability to re-open the polls
- ❖ Grouping of undervotes and overvotes on reports
- ❖ Automatic certification report printing when polls are closed
- ❖ Automatic results report printing when polls are closed
- ❖ Rejection, acceptance or query the voter when a scanner detects an overvoted, undervoted or blank ballot



Note: Screen text that ends with an ellipsis (...) indicates that more characters were entered for the text in ElectionWare than the DS200 can display

Election Security

The USB flash drive containing the election definition and election totals is secured under a locked panel. A provision for a wire seal within the USB port provides an additional level of security. The DS200 records errors and major events and tags these incidents with the date and time the incident occurred based on the DS200's real-time clock settings. Audit trails are saved to the inserted USB flash drive. The Zero Report, which is printed before polls are open on Election Day, is used to indicate no tampering has been done to the vote totals.

The DS200 also has the capacity for redundant storage of election day information. The USB flash drive used for redundant data storage is located in the back of the machine, and is sealed under a locked panel prior to election day.

The DS200 has a laptop-style hinge display that doubles as a built-in security lid. Until this lid is unlocked and opened, there is no access to the paper path or other optical components. After poll workers mount the DS200 into the ballot box, a door on the ballot box hinges into place at the front of the DS200 and locks the DS200 unit into place. The ballot box is equipped with key locks that prevent access to the ballot compartments storing the paper ballots, the DS200 unit and the ballot slot. After poll workers close the polls, users cannot cast ballots without the proper ballot box keys and security codes to reopen the polls.

The USB flash drive stores images of each ballot cast. To ensure security, the ballot images are stored with random names assigned to each ballot image file to protect voter anonymity. Image storage is an option set in ElectionWare. You can select to save all, save only images of ballots with write-ins, or don't save any images at all. The system automatically saves XML records of each ballot cast.

Part 2: Using the DS200 in an Election

Part 2 contains information about the following topics.

- ❖ [Chapter 4: Pre-Election Day Tasks](#)
- ❖ [Chapter 5: Election Day Tasks](#)
- ❖ [Chapter 6: Post Election Day Tasks](#)

Chapter 4: Pre-Election Day Tasks

Use the equipment list and the procedures in this chapter to prepare your DS200 scanner for a live election. Always perform routine maintenance on your voting equipment and test your ballot scanners before you open the polls on Election Day.



Reference: For instructions for opening and closing the polls, operating the scanner during an election and printing or transferring results, see [Chapter 5: Election Day Tasks](#).



Reference: In accordance with section 7.4.1 in Volume 1 of the Election Assistance Commission's Voluntary Voting System Guidelines, users must validate the firmware on the power management board, scanner control board, and the internal compact flash card before the start of election operations.

Recommended Supplies

ES&S recommends maintaining a supply of the following items for each DS200 used in your jurisdiction. All of the listed items are available for order from ES&S.



Contact ES&S customer service at 877-377-8683 with any questions or orders. Allow four weeks for delivery.

See the ES&S Supply Catalog for a list of available products at www.essvote.com.

- ❖ **Paper Rolls:** The printer uses NCR 3.13" by 80' thermal paper rolls. The NCR part number is 2200. **Recommended Quantity: 1 full roll per scanner**
- ❖ **USB Flash Drive:** A USB flash drive stores the scanner's election definition, ballot count and ballot images. The standard memory capacity for each flash drive is 1 to 8 GB. **Recommended Quantity: 2 per scanner**
- ❖ **Seals:** Use wire and tamper evident seals to secure the scanner, ballot and tote bins. **Recommended Quantity: Determined by your jurisdictions security requirements.**



See [DS200 Seals and Locks](#), [DS200 Carrying Case and Ballot Bin Security Seals](#), [Steel Ballot Box](#) and [Closing and Removing the DS200 Tote Bin from the Plastic Ballot Box](#) for recommendations for securing the DS200, ballot bins and tote bins.

- ❖ **Marking Devices:** ES&S recommends and supplies the Bic Grip (Black) medium point roller ball pen for voters to mark ballots.
- ❖ **Pressurized air cans:** Use pressurized air to clean the scanner. **Recommended Quantity: 2 cans per scanner**

- ❖ **Lint-free cloth:** Use for general cleaning purposes.
- ❖ **Cleaning pad and isopropyl rubbing alcohol:** Use isopropyl alcohol to clean the scanner rollers, CIS sensors and LCD screen. If you order the cleanser from ES&S, the part identifier is ES-Cleaner. To clean the scanner rollers, pour the cleanser into a spray bottle and dampen the cleaning pad. Never spray cleanser directly on the scanner. You can also use alcohol swipes to clean the scanner. **Recommended Quantity: 1 bottle per scanner**

Attach the DS200 to the Ballot Box

- ❖ If you are using the plastic ballot box, follow the instructions under the [Assemble the Plastic Ballot Box](#) and [Attach the DS200 to the Plastic Ballot Box](#) headings.
- ❖ If you are using the metal ballot box, follow the instructions under the [Attach the DS200 to the Metal Ballot Box](#) heading.

Assemble the Plastic Ballot Box

1. Place the emergency ballot storage bin into the ballot box.
2. Use the side bars from the DS200 carrying case to lift it above the ballot box.

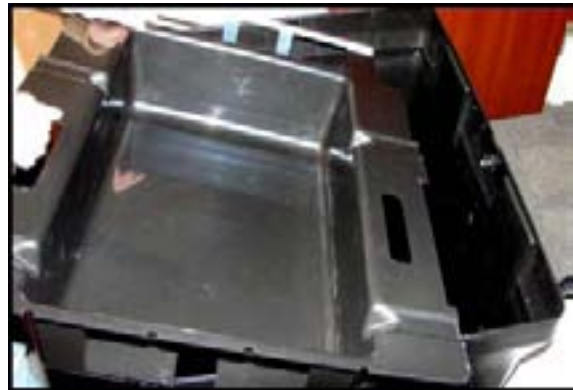

3. Place the DS200 carrying case above the ballot bin. Make sure the wheels from the carrying case fit into the holes in the emergency ballot bin.

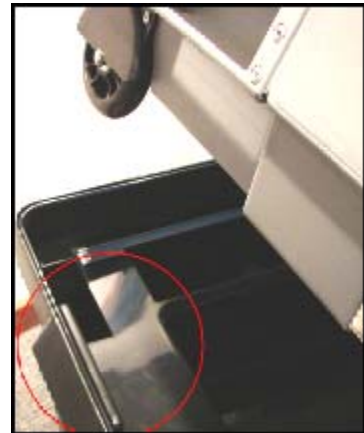

4. Use the ballot box key to lock the left and right sides of the carrying case into place.



Attach the DS200 Power Source to the Plastic Ballot Box

1. Use the ballot box key to unlock the rear panel of the DS200.



2. Place the DS200 power source behind the two bands in the back of the DS200 carrying case.



3. With the metal bar in the up (locked) position, locate the P-Clamp on the left side of the plastic ballot box.

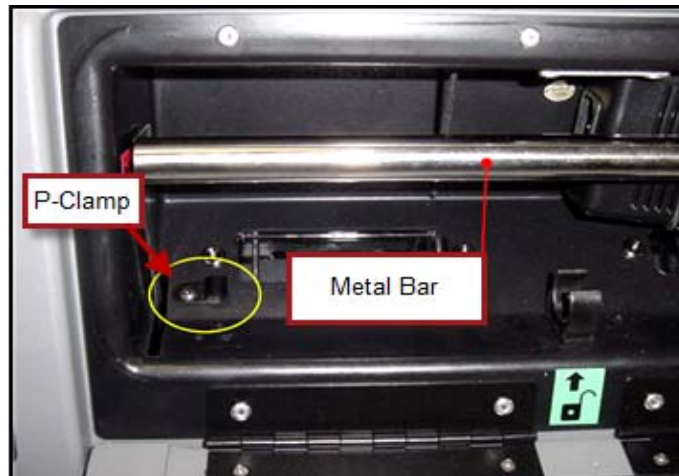

Warning: You must move the metal bar into the locked position before you open the DS200. If the metal bar is in the unlocked position, ballot jams will occur.

- Using a #2 Phillips screwdriver or a power screwdriver with a #2 bit, remove the P-Clamp.



Note: If you are using a power screwdriver, make sure the torque setting is on its lowest setting to prevent damage to the plastic molding.



- Once the P-Clamp is removed, make sure you have all three of the following items:

- #6 Phillips sheet metal screw
- P-Clamp
- #6 External star washer



- Open the P-Clamp wide enough to slide over the power cord. Place the clamp about 3 inches away from the female end of the power cord. After sliding the P-Clamp over the cord, make sure the mounting hole is to the left of the power cord.



P-Clamp



Caution: Do not open the P-Clamp too wide, this could cause the clamp to crack or break.

7. Place the #6 sheet metal screw through the mounting hole. On the underside of the P-Clamp, place the #6 external star washer.



8. Using a #2 Phillips screwdriver or a power screwdriver with a #2 bit, screw the P-Clamp back into its original place in the plastic ballot box. **DO NOT** tighten the P-Clamp at this time.



Caution: If you are using a power screwdriver, make sure the torque setting is on its lowest setting to prevent damage to the plastic molding.

There should be approximately seven inches from the female end of the power plug to the top of the P-Clamp. This will make it easier to replace the DS200 power supply.

9. Connect the end of the AC power cord into the DS200 power supply



10. Tighten the #6 sheet metal screw in the P-Clamp. **Do not** over-tighten the screw.



11. Thread the cord on the opposite side of the power cord through the hole next to the power supply.



12. Go to the front of the DS200 carrying case and pull the cord below the two metal ballot path guides. Pull out the Power Cord Guard and pull through the full length of the power cord. Be careful that the power cord does not catch on the side of the Power Cord Guard.

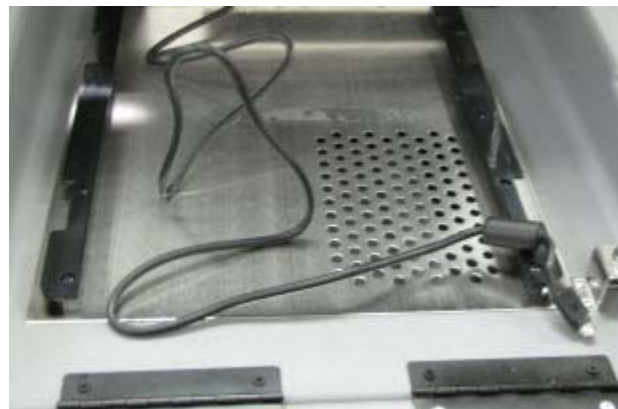

13. Loop the excess of the power cord, and leave about seven inches of the cord loose.



14. Put a plastic tie around the cord to secure the cord and to keep it from unwinding.



15. Lay the power cord inside the Power Cord Guard.

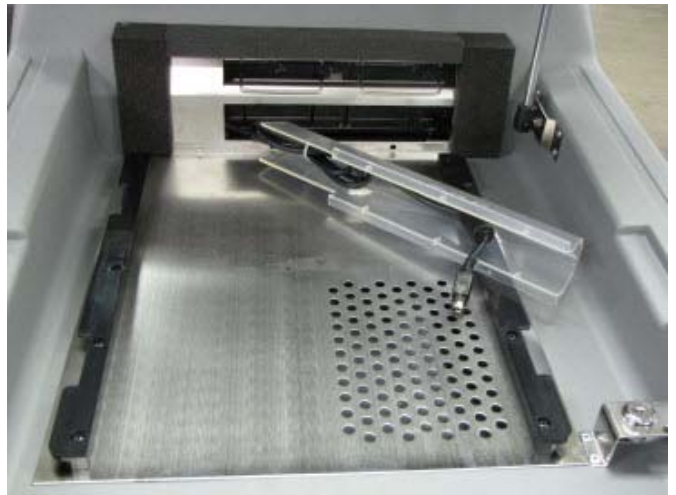

- 16. Take the AC plug and place it near the center of the ballot box, the AC plug will lay approximately one inch from the Power Cord Guard.

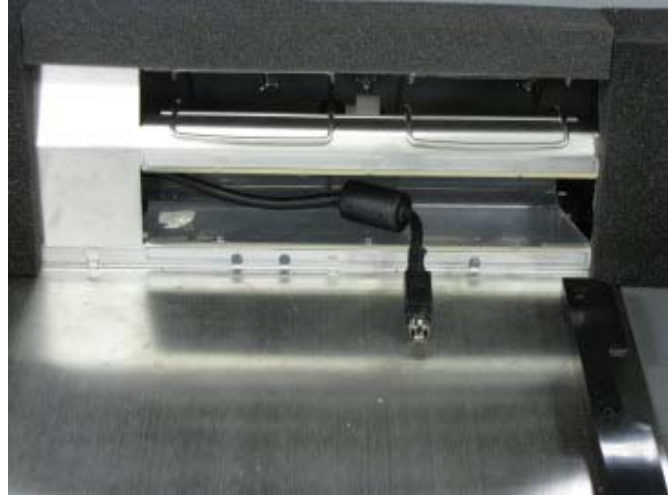

- 17. After you attach the DS200 to the ballot box, plug the power cord into the back of the DS200 and then plug it into an AC outlet.

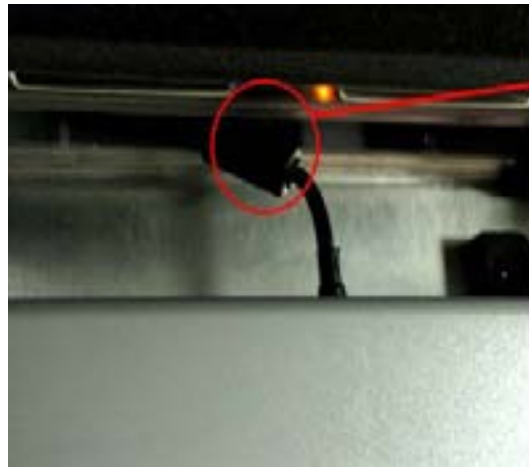

Ensure the ferrite stays to the left of the plug.

No part of the cord should appear in the ballot path.

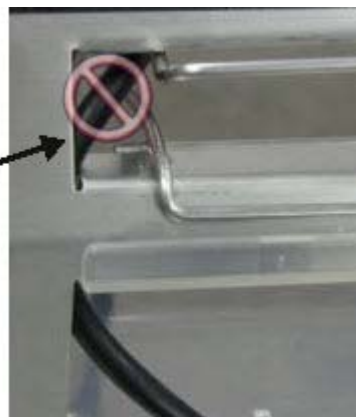

Warning: Once you tie the DS200 cord, make sure no part of the cord can be seen where the ballot path lies. If any part of the cord is in the ballot path, ballot jams will occur when the DS200 is in voting mode.

Attach the DS200 to the Plastic Ballot Box

1. Use the ballot box key to open the front of the DS200 carrying case.
2. Press up on the two tabs to unlock the DS200 carrying case.
3. Inspect the power cord for damage before you mount your scanner to the top of the ballot bin.



Electrical Shock Danger: If the cord appears damaged, discard it and contact ES&S for a new cord.

4. Place the scanner about one-third of the way into the recessed area and slide it onto the mounting rails until it sits about four or five inches (0.1 meters) from the back of the recessed area.



Warning: Only plug the DS200 scanner into a grounded, three-pronged electrical outlet. Plug only one scanner into each available outlet. ES&S does not recommend using an extension cord.

5. Plug the power cord into the power port on the back of the scanner and then plug the AC power cord from the external power supply into a 120-volt wall outlet. Arrange your voting equipment to make sure that no one trips on the cord or accidentally unplugs the scanner on Election Day.



Note: A “No Input Power Detected” message appears on the scanner’s display screen and a “Switched to Battery Power” message is added to the audit log if the scanner is not receiving power through the power cord. Check your connections and the wall outlet if this message appears on your scanner’s display screen. After the scanner has been re-connected through the power cord, a “Switched to AC Power” message is added to the audit log.

6. Slide the scanner against the back of the DS200 carrying case. The scanner will press against the two protective foam inserts.



7. Insert the ballot box key into the lock inside the DS200 carrying case and securely lock the DS200 onto the metal rails.
8. Raise the hinged access door on the DS200 carrying case and lock the hinged door into place to secure the scanner in the carrying case.



Test the door to make sure the lock properly engages. If the door cannot be locked, the DS200 may not be pushed completely up against the back of the DS200 carrying case.

Seals and Locks

DS200 Seals and Locks

1. Insert the USB flash drive containing the election definition.
2. Secure the USB flash drive with a seal.
3. Close and lock the front access door. Assure that the front access door is locked and place a tamper evident seal as shown.
4. Insert the USB Backup Memory Device in the rear compartment. If your election rules require the use of a backup memory device, you should secure the USB Backup with a seal.
5. Close and lock the rear access door. Assure that the rear access door is locked and place a tamper evident seal as shown..
6. Close the display and lock. A tamper evident seal may be placed vertically from the lock to the display as shown.



DS200 Carrying Case and Ballot Bin Security Seals

The DS200 carrying case and ballot bin has nine possible locations for wire-type seals.

A. To secure the carrying case to the bin, engage the locks on the sides of the bin between the handles, then place one seal on each side of the bin between the handles (two seals).

B. To secure the ballot bin, assure that both doors are locked and place one seal on each door (two seals).

C. To secure the carrying case lid, secure both lid latches and lock the lid using the lock between the two latches. Place at least one seal on the lid latch. There are two locations for seals on each latch. Only one seal should be necessary to secure the lid.

D. To secure the DS200 inside the carrying case, lock the front door and place a seal through the lock bracket.

E. Further polling site security may be attained by using the integrated anchor point on the DS200 Ballot Bin.



Note: ES&S does not recommend any specific lock for this application due to the unknown anchor points at your polling sites. Check with your local hardware, sporting goods or computer supply store for options.

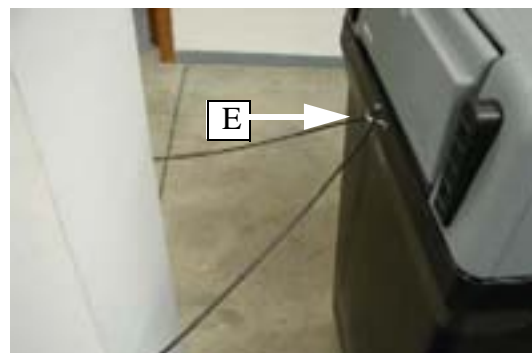
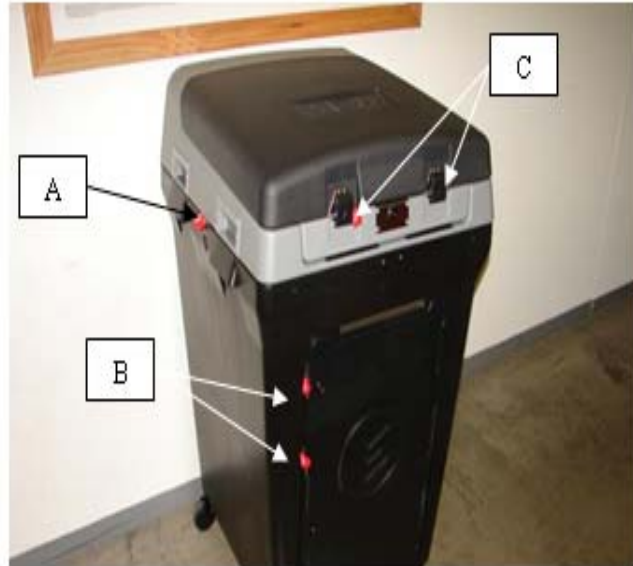

Steel Ballot Box

The steel ballot box has six possible locations for seals.

A. Slide the tabulator onto the ballot box rails and secure. A tamper evident seal can also be added for additional security.

B. Access to the emergency ballot bin is limited by this lock. A tamper evident seal can also be added for additional security.

C. When the scanner is in operation the ballot flap must be in the up position. During storage, transportation or periods of higher security, the ballot flap should be in the closed position and locked, using the lock next to the ballot flap.

D. Access scanned ballots through doors located on each side of the ballot box. These doors should be locked, and a tamper evident seal can also be added for additional security.

E. Additional security can be implemented by adding a seal on the bottom of the ballot box door.

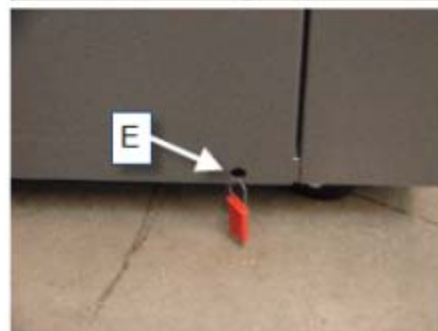
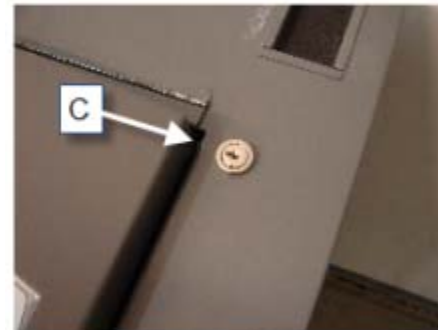

Attach the DS200 to the Metal Ballot Box

The metal ballot box does not require assembly. Take the following steps to attach the DS200 to the Ballot Box.



Warning: Do not transport the DS200 while attached to the metal ballot box. The DS200 should be delivered separately in the tabulator's storage and transport case and attached to the metal ballot box at the polling location.

1. Before you mount your scanner to the top of a ballot box, inspect the power cord for damage.



Electrical Shock Danger: If the cord appears damaged, discard it and contact ES&S for a new cord.

2. Insert the DS200 power cord from the external power supply through the opening on the outer left side of the ballot box.
3. Thread the cord through the outside opening on the back of the box until the cord appears on the inside of the opening at the top recessed area.
4. Pull the cord through the opening until it extends a few inches into the recessed area of the ballot box.
5. Remove the scanner from the carrying case.
6. Place the scanner about one-third of the way into the recessed area and slide it onto the mounting rails until it sits about four or five inches from the back of the recessed area.

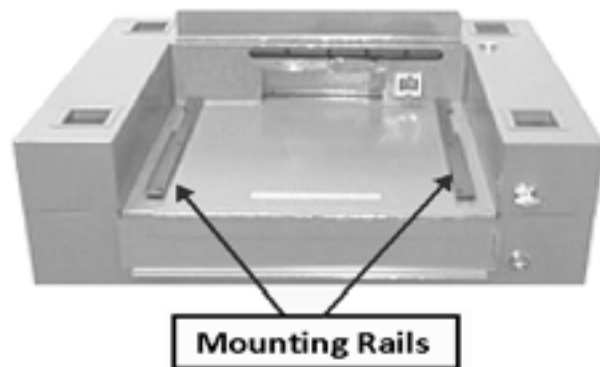

Electrical Shock Danger: Only plug the DS200 scanner into a grounded, three-pronged electrical outlet. Plug only one scanner into each available outlet. ES&S does not recommend using an extension cord.

7. Slide the scanner against the back of the ballot box. Make sure the diverter connector at the back of the scanner locks into the slot on the ballot box.

8. Plug the power cord into the power port on the back of the scanner and then plug the AC power cord from the external power supply into a 120-volt wall outlet. Arrange your voting equipment to make sure that no one trips on the cord or accidentally unplugs the scanner on Election Day.

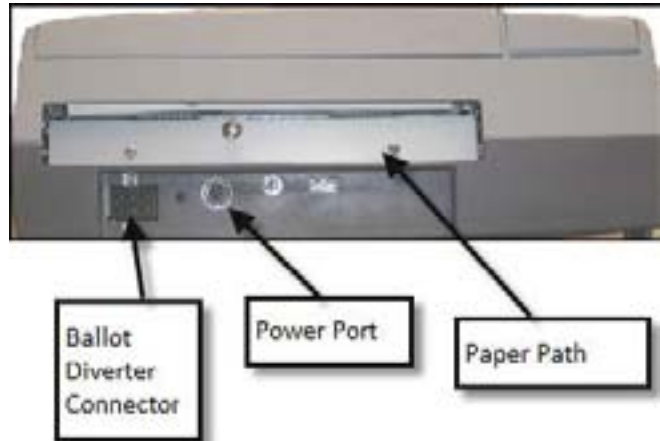

Note: A “No Input Power Detected” message appears on the scanner’s display screen and a “Switched to Battery Power” message is added to the audit log if the scanner is not receiving power through the power cord. Check your connections and the wall outlet if this message appears on your scanner’s display screen. After the scanner has been re-connected through the power cord, a “Switched to AC Power” message is added to the audit log.

9. Raise the hinged access door on the ballot box and lock the hinged door into place to secure the scanner in the ballot box. Test the door to make sure the lock properly engages. If the door cannot be locked, the DS200 may not be pushed completely up against the back wall of the ballot box.

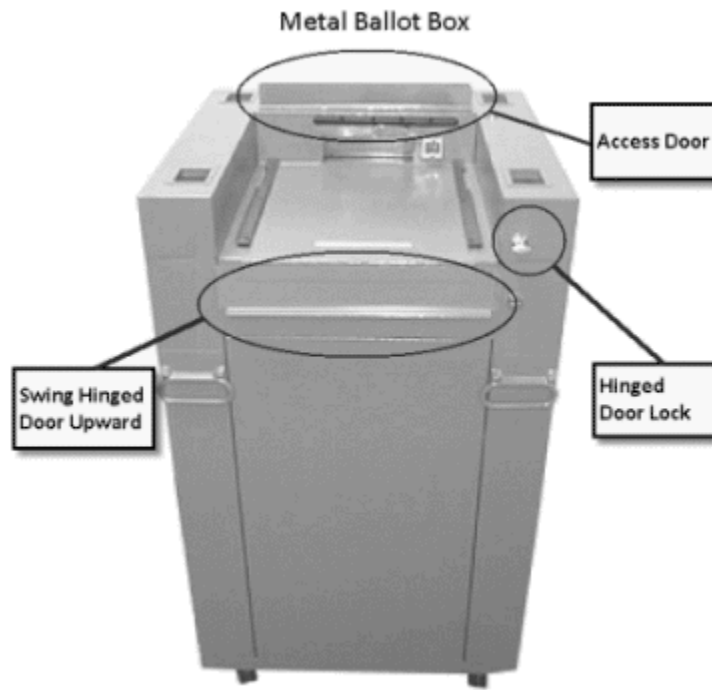

Tote Bin (optional)

Preparing the DS200 Ballot Box to receive the Tote Bin

1. Insure that the front locking casters are pointing out the side of the Ballot Box to reveal the locking mechanism. Gently step on the locking mechanism tab to securely lock the caster in place. This will insure that the Ballot Box does not move when the Tote Bin is inserted or when it is removed from the Ballot Box.



2. After removing the seal, unlock the Lower Bin Door. Verify that there is nothing inside the Lower Bin that would hinder the Tote Bin to be inserted.

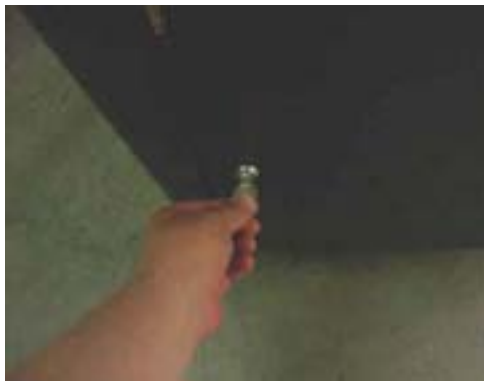

Inserting the DS200 Tote Bin into the Plastic Ballot Box

3. Before inserting the Tote Bin into the DS200 Ballot Box Lower Bin, unlock both locks located on the Top Front and Top Back on the Tote Bin Doors.



4. Align the backside of the Tote Bin so that the Back Alignment Feet are between the Inside Guide Rails.

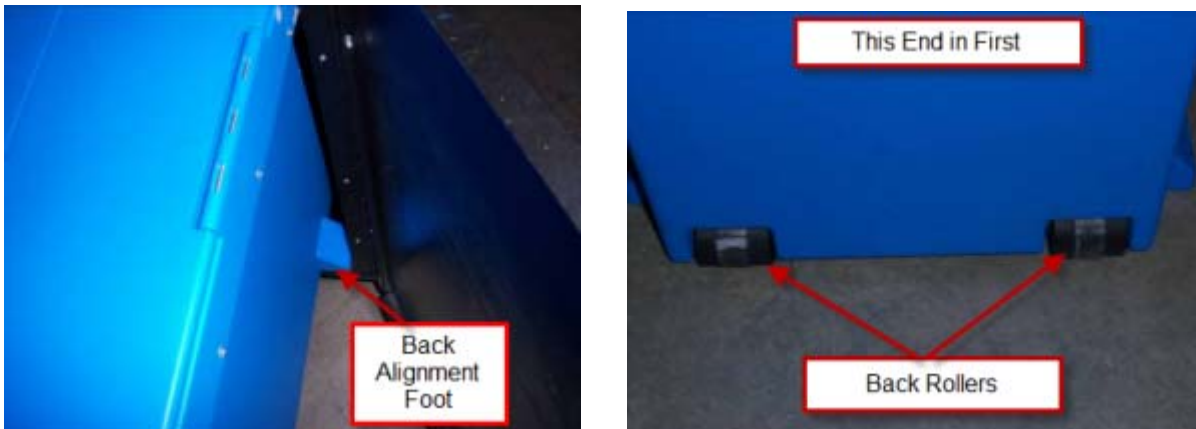

5. Use the Strap Handle on the front of the Tote Bin to lift up and slide the Tote Bin completely into the Lower Bin. The Tote Bin should slide in until the front of the Tote Bin is even with the opening of the Lower Bin



6. Once the Tote Bin is completely inside the Lower Bin, open both lids to expose the inside of the Tote Bin. The lids should rest on the inside of the Lower Bin.



Note: Both Lids must be opened fully in order for Ballots to properly fall and stack inside the Tote Bin.



Reference: To close and remove the Tote Bin from the Ballot box, see [Closing and Removing the DS200 Tote Bin from the Plastic Ballot Box](#).

Prepare the Counter

After you mount the scanner to the ballot box, there are a number of tasks that you must complete before you open the polls. Because the proper operation of the counter depends on performing the following tasks, it is important to carefully review this section before every election.

Loading New Firmware

Your DS200 should be pre-loaded with the latest firmware version. However, if you need to perform a firmware update please follow the instructions below.



Warning: Only update firmware when approved by your State Election Authority.

To install new firmware on the DS200

1. Load the firmware update onto the USB flash drive.
2. Unlock the access door to the DS200 and remove any USB flash drives. If the DS200 is turned off, press the power button to turn on the DS200.



The Configuration report will print and the following screen will appear.



3. Insert the USB flash drive containing the firmware update into the DS200 (slot A,B or C, under the locked cover next to the printer). An Upload New Firmware screen appears.

4. Press continue, to begin updating the firmware. The update process will take several minutes. **PLEASE WAIT.** During the update a text script will begin to scroll across the display. When the update has finished the text will display **“Update completed, remove the USB update before rebooting the system”**.
5. Remove the USB flash drive and then press and hold the power button down until the DS200 shuts off, then release the button.
6. With the USB flash drives removed, press the power button to start the DS200. The opening screen will appear and the Configuration report will print. Compare the new configuration report with the first one from step 3 to verify the upgrade was successful.



Note: When you turn on the DS200, the firmware version will appear on the configuration report.



Note: The firmware update does not affect or change the Protected Count on the DS200

Charge the Battery

The DS200 uses a backup battery to ensure that scanner operations continue without interruption during a power failure. Plug the scanner in and turn on the power.

Check the Battery Charge

1. Turn on the DS200. After the scanner powers up, the following screen appears.
2. Press **Admin**. The Voting Device Status screen appears.







Note: If you have loaded your definition this screen will look different.

3. The battery power icon , located in the upper-right region of the screen, displays the battery's charge. The battery is charging whenever the power cord is plugged into the unit. If the battery does not show a full charge, continue to supply power to the unit until it reaches a full charge. The amount of charge time required to fully charge the battery depends on the current status of the battery icon.



Use the following charge guidelines to estimate charge time

 Full battery charge	If the battery shows a full charge, the DS200 does not need charging
 75 percent charge	It should take about 2 to 3 hours of fully charge the battery.
 50 percent charge	It should take about 3 to 4 hours to fully charge the battery.
 25 percent charge	It should take 5 to 7 hours to fully charge the battery.
 No charge	It should take 5 to 7 hours to fully charge the battery.

USB Backup Memory Device

The DS200 supports automatic archiving of the results data through the use of a Backup Memory Device (USB memory stick). The Backup Memory Device is optional, and depends upon the rules your jurisdiction has regarding redundant storage. You may implement the USB Backup Memory Device without any software configuration changes.

To Configure the DS200 to use a Backup Media Device will require you to select a DS200 compatible memory device, with a data size equal to or greater than the Election Media device. This USB memory device is then inserted in the device in the auxiliary USB port, located under the rear locking cover.

Install the Backup Memory Device

1. Unlock and open the rear access door. If a security seal is placed on the access door, follow your jurisdictions guidelines for removing and recording security seals.
2. Locate the auxiliary USB port, and insert the USB Backup Memory Device.
3. Secure the USB Backup Memory Device with a seal.
4. Close and lock the rear access door. If a security seal needs to be replaced on the access door, follow your jurisdictions guidelines for replacing security seals.

DS200 Backup Media Device Set-up

Once the Backup Memory Device is installed and the DS200 is powered up, you will print a Configuration report. The Configuration report identifies the size of the Backup Media Device as “Backup Space Available: <XXXX MB>” (XXXX being the amount of available space in MB). If the Backup Space Available indicates a non-zero number the Backup media device has been detected.



Note: A zero number without a Backup Media Device installed is normal. This indicates there is no Backup Media in the machine.



Note: Secure the Backup Media Device with a wire seal prior to polling use.

Clear the DS200

Before loading the election definition, you will need to clear the DS200. Clear the DS200 by inserting a clear memory device, called the EQC media, into the DS200. Once the device is inserted into the DS200, and you enter the correct security code, the following actions occur:



Note: If you are using a USB Backup Memory Device, you must insert it before clearing the DS200.

- ❖ The election log from the previous election is cleared.
- ❖ The Backup Memory Device is erased of all content.
- ❖ Loads the EQC for the DS200.
- ❖ Loads the EQC code onto the Backup Memory Device if a backup device is inserted.
- ❖ Loads all the security codes that were set in ElectionWare.



Reference: Refer to the *ElectionWare System Operations Procedures* manual for more information about creating a clear memory device.

1. Lift the access door on the front left of the scanner to access the USB flash drives.

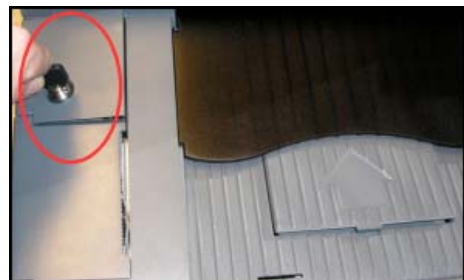

2. If necessary, remove the protective plastic covering of the USB flash drive containing the clear media.
3. Insert the USB flash drive into one of the USB ports. Do not force the flash drive into the slot.



Important: If a backup media device is required, the Backup Media Device **MUST** be installed prior to installing the EQC Clear media device. If the Backup Media Device is not installed, the DS200 will reject any attempt to open the DS200.

4. Turn on the DS200; a Clear and Initialize screen appears.
5. Press **Continue**; the Enter Qualification Code screen appears.

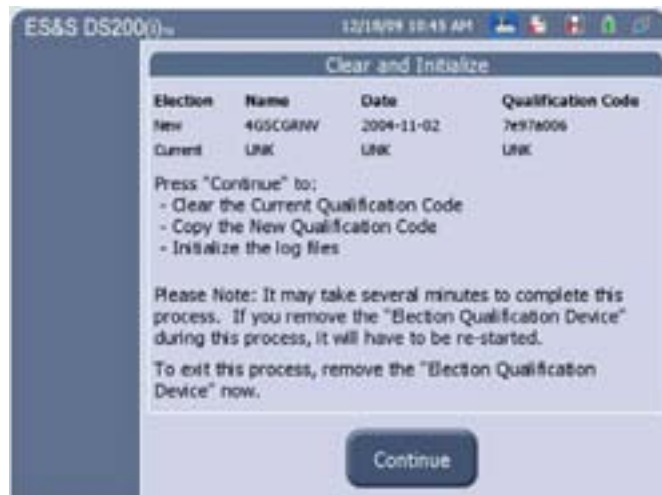

6. Enter the EQC code used to clear the DS200.
7. Press **Accept**.



The system initializes itself and displays the following message when completed.

8. Remove the EQC media device from the USB port.



Load the Election Definition

DS200 tabulators use the election definition programmed on USB flash drives to recognize ballot marks and tabulate results.



Warning: Ensure that DS200 USB memory devices are correctly partitioned and properly formatted to the FAT32 file system prior to loading devices with election configuration files.

If you do not have a definition loaded when you turn on the DS200, you will receive an “Election Definition Not Found” message.

1. Lift the access door on the front left of the scanner to access the USB flash drives.
2. If necessary, remove the protective plastic covering of the USB flash drive containing your election definition.

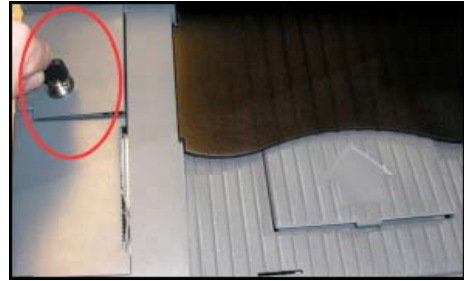

3. Insert the USB flash drive into USB ports A or B. Do not force the flash drive into the slot.

Caution: The flash drive has a slot on top for wire seals. If wire seals are used to secure the device, route the wire through this slot and through the associated seal hole on the tabs next to the flash drive wells.



4. If the DS200 was powered off turn it on, then the Election Code screen appears.
5. Enter your code and press **Accept**.



The Configuration Report will print, the following screen appears notifying you that the election definition was found.



Check the Election Definition for Accuracy

The DS200 automatically generates a Configuration Report when you start the scanner. Check the report for the following information:

- ❖ **System Values:** Make sure the date and the time appear correctly on the report. If the information is not correct, change date and time from the Systems Setting screen.



Reference: For more information about changing the date and time settings for the scanner, see the [Change Date and Time Settings](#) heading in this chapter.

- ❖ **Election Information:** Make sure that the jurisdiction name, polling place, and the number of Precincts listed on the report are correct.

Administration Menu

After you insert an election definition and start the scanner, the message, “Election Definition Found” appears on the screen.

1. Press the **Admin** button in the upper-right region of the screen to access the Administration Menu.



Note: You cannot access the Administration Menu screen if you do not have an election definition installed.

2. Once you press the **Admin** button, the Voting Device Status screen appears.



3. Press **Log In**. The Administration Code screen appears.



4. Use the buttons on the screen to enter your security code and press **Accept** to access the Administration Menu screen.



The following screen appears.

5. Access the following screens from the Administration Menu screen:
 - ❖ Press **Ballot Diagnostics** to open the Ballot Diagnostics screen. The following options are available from this screen:
 - Press **Scan Ballot** to scan a ballot through the DS200. Use the onscreen keypad to enter the number of times you wish to scan a single ballot.
 - Press **Reports** to print or view an onscreen copy of the **Mark Code** or **Digital Readings** reports.
 - ❖ Press **Hardware Diagnostics** to perform the following tasks:
 - Press **Hardware Reports** to print a hardware configuration report.
 - ❖ Press **System Settings** to perform the following tasks:
 - Press **Date and Time Options** to change the scanners date and time settings.
-  **Reference:** See the [Change Date and Time Settings](#) heading in this chapter for more information about changing the time and date settings.
- Press **Hardware Settings** to calibrate the scanner.

- Press **Calibrate Touch Screen** to calibrate the touch screen on the DS200.



Reference: Some jurisdictions require that the firmware loaded onto the DS200 be validated prior to deploying the machines in an election. You can create media to validate firmware from the Administration menu.

See [Optional Step: Create Media to Validate Firmware](#) for additional information.



Reference: Some jurisdictions want to configure the DS200 so that their poll workers do not have to enter a security code to enter voting mode. You can configure your DS200 to not require a security code from the Administration window.

See [Optional Step: Configuring the DS200 to Not Require a Security Code to Enter Voting Mode](#) for additional information.

Ballot Diagnostics

Use the Ballot Diagnostics menu to test the scanner's ability to scan a ballot. From this menu, you can generate test ballot reports as well as test the ballot diverter. You can also test the printer by pressing the **Use Printer** box in the Scan ballot screen.



Note: The Ballot Diagnostics menu should be accessed by a certified ES&S Technician. See the *DS200 System Maintenance Manual* for procedures.

Scan Ballot

Use the Scan Ballot option to perform a ballot test for the DS200 and the ballot diverter if you are using a ballot diverter. The results will appear in the **Reports** menu option, located below the **Scan Ballot** menu option.



Note: If the election is set up to save no ballot images, the DS200 will not save any ballot images or cast vote records and the public and protected counters will not increment. This is a feature specifically used for hardware testing and should not be used to validate the tabulator's mark detection accuracy during L&A.

Reports

Once you have scanned your ballots under the Ballot Diagnostics menu, run a report to view the results of the test scan. Two options are available:

- ❖ Select **Mark Code** to generate a report that shows the different types of marks recognized by the scanner in each response area.
- ❖ Select **Digital Readings Report** to generate a report that shows how many pixels the scanner reads in each oval location.

Hardware Diagnostics

Hardware Diagnostics displays your hardware settings. Use the options under the Hardware Diagnostics menu before and after an election to verify that all scanner functions work correctly.

Hardware Reports

Hardware Reports display the status of the DS200. The Hardware Configuration report shows such information as the scanner's memory and storage capacity, diverter status and firmware version.

1. From the Administration menu, press **Hardware Diagnostics**. The Hardware Diagnostics screen appears.

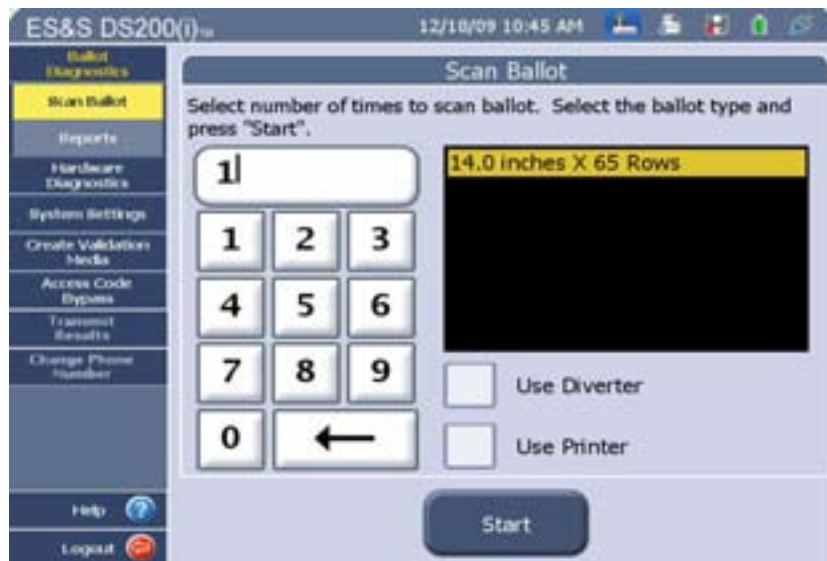

2. Press **Reports**. The Reports screen appears.



3. Press **Hardware Configuration Report**.
4. Press **Preview** to view a preview copy of the Hardware Configuration Report on the screen. Press **Print** to generate a hard copy report.

Sample Hardware Configuration Report

```

*** CONFIGURATION REPORT ***
9:40 AM January 18, 2011
Unit Serial Number: 0107370046

VOTING DEVICE INFORMATION

HARDWARE CONFIGURATION
Current Time Date:
  9:40 AM January 18, 2011
Time Zone: America/Chicago
Diverter Status: Not Detected
Touch Screen: OK
Power Source: AC
Battery Charge: 100%
Modem Status: Not Detected
Universal Voting Console: Not Detected

STORAGE
Available System Log Storage: 22 MB
Available Ballot Storage: 1751 MB
Available Backup Storage: 0 MB

FIRMWARE
Paper Processing Engine: 2.4.0.0x
Hardware Abstraction Engine: 2.4.0.0x
Tabulation Engine: 2.4.0.0x
Scanning Engine: 2.4.0.0x
Presentation Engine: 2.4.0.0x
Scanner Firmware: 2.13.0.0a
Power Management Firmware: 1.2.2.0a
Operating System Version: 2.4.0.0x
Firmware Last Updated On:
  Unknown
Protected Count: 0

ELECTION QUALIFICATION INFORMATION
Election Name: TULSA
Election Date: 2010-12-31
Election Qualification Code: 09b1e725

ELECTION LOADED

ELECTION STATUS
Poll Opened Date: January 11, 2011
Poll Opened Time: 4:31 PM
Poll Closed Date: January 11, 2011
Poll Closed Time: 4:44 PM
Poll Status: Closed
Public Count: 1

ELECTION INFORMATION
Jurisdiction Name:
  TULSA
Election Description:
  TULSA
Election Date: December 31, 2010
Poll Place ID/Name:
  863/Poll 001
Election Type: GENERAL
Number of Precincts: 1

BALLOT INFORMATION
Ballots By: Style
Ballot Height: 17.0
Ballot Width: 8.5
Ballot Rows: 62
Ballot Columns: 24
Ballot Art Work: DSIM
Target Type: oval

ELECTION SETTINGS
Ability to Re-open: Yes
Number of Zero Tapes to Print: 1
Number of Result Tapes to Print: 1
Print Event Log on Close: No
Transmit Results on Close: No
Report Detail: Media
Report Level: Poll
Candidate Sort Order:
  Default Candidate Order
Single Over-Vote: No
Combine Over and Under Votes: No
Save Ballot Images: All

EXCEPTION BALLOT SETTINGS
Blank Ballots: Query
Over-voted Ballots: Query
Under-voted Ballots: Query
Marginal Marks: Reject
Cross-over Ballots: Query

DIVERTER SETTINGS
Diverter Installed: No
Identify Write-in Overvotes: No
Identify Blank Ballots: No
Identify Write-ins: No

*** END OF REPORT ***

```

System Settings

Use the System Settings menu to perform tasks such as changing the date and time as well as calibrate the scanner and calibrate the touch screen.

Change Date and Time Settings

Use **Date and Time Options** from the System Settings screen to change the scanner's date and time settings.

1. From the Administration Menu, press the **System Settings** button. The System Settings screen will appear.

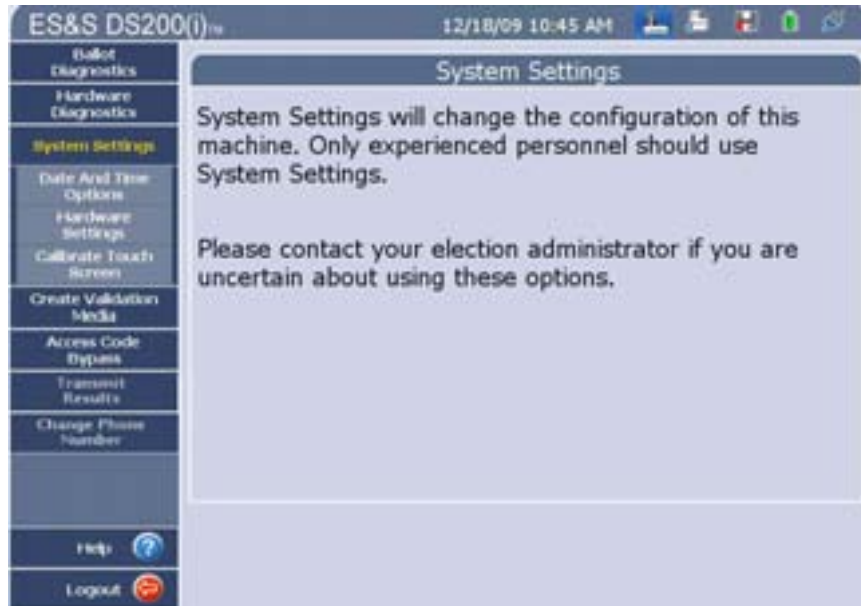

2. Press the **Date and Time Options** button. The Date and Time Options screen will appear.



Change the Date

- From the Date and Time Options screen, press **Change Date**. The Change Date screen appears.



- Press the day you wish to change to. If you need to change the month, press the **Left** and **Right** arrows next to the current month.
- Press **Apply** to save your changes or press **Reset** to go back to the previous date setting.
- Press **Back** to return to the Date and Time Options screen.

Change the Time

- From the Date and Time Options screen, press **Change Time**. The Change Time screen appears.

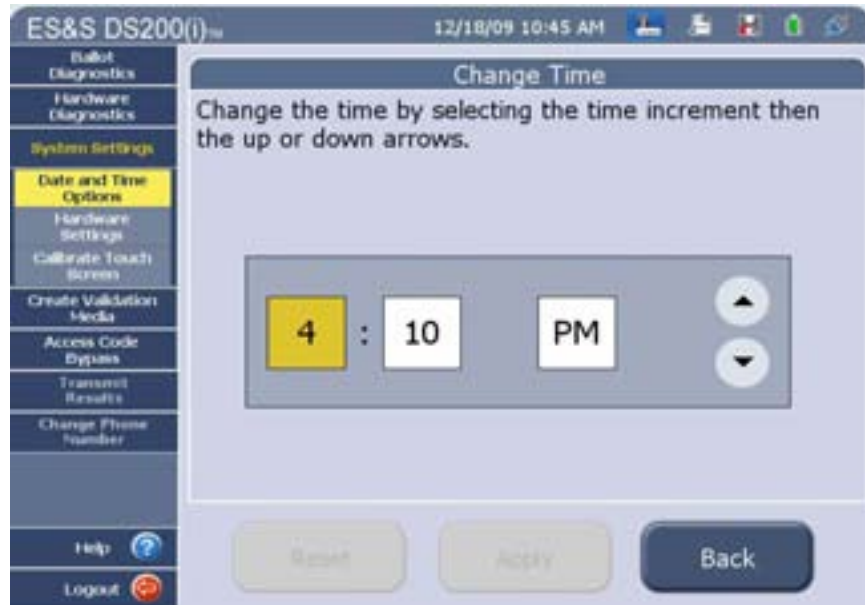

- Press one of the following boxes to select part of the time you want to change: **Hour**, **Minute** or **AM** or **PM**.
- Use the **Up** and **Down** arrow to make your changes.
- Press **Apply** to save your changes. Press **Reset** to go back to the previous time setting.
- Press **Back** to return to the Date and Time Options screen.

Change The Time Zone

From the Date and Time Options screen, press **Change Time Zone**. The Change Time Zone screen appears.



12. Use the yellow **Up** and **Down** scroll arrows to locate your time zone.
13. Press **Apply** to save your changes. Press **Reset** to go back to the previous time zone setting.
14. Press **Back** to return to the Date and Time Options screen.

Save Your Time Settings

15. Once you have made all of your time settings, make sure you are in the Date and Time Options screen.
16. Press **Apply** to save your changes. Press **Reset** to erase your time changes.
17. After you press **Apply**, a verification screen will appear. Press **OK** to continue.



You must press **Apply** on the Date and Time Options screen to save your date and time changes. If you try to exit this screen without saving your changes, a warning screen will appear notifying you that the changes have not been saved.

Hardware Settings



Note: The Hardware Settings menu should be accessed by a certified ES&S Technician. See the *DS200 System Maintenance Manual* for procedures.

Top CIS Threshold & Bottom CIS Threshold

ES&S Technicians set the brightness threshold for the top and bottom image sensors



Note: The Top CIS Threshold and Bottom Threshold menu should only be accessed by a certified ES&S Technician. The default value should be 150. See the *DS200 System Maintenance Manual* for procedures.

Calibrate Scanner

Use the Calibrate Scanner function to recalibrate the DS200 scanner.

Recalibrating the DS200 scanner will normalize the photo sensors in the contact image sensor. You should run scanner calibration:

- Before each election or approximately 10,000 ballots in extended election mode
- When firmware is updated.
- When maintenance is performed on the unit.



Note: The Calibrate Scanner menu should only be accessed by a certified ES&S Technician. See the *DS200 System Maintenance Manual* for procedures.

Calibrate the Touch Screen

Calibrate the DS200 touch screen to ensure the touch screen functions on the scanner work correctly.

1. From the Administration menu, press **System Settings**. The System Settings screen will appear.

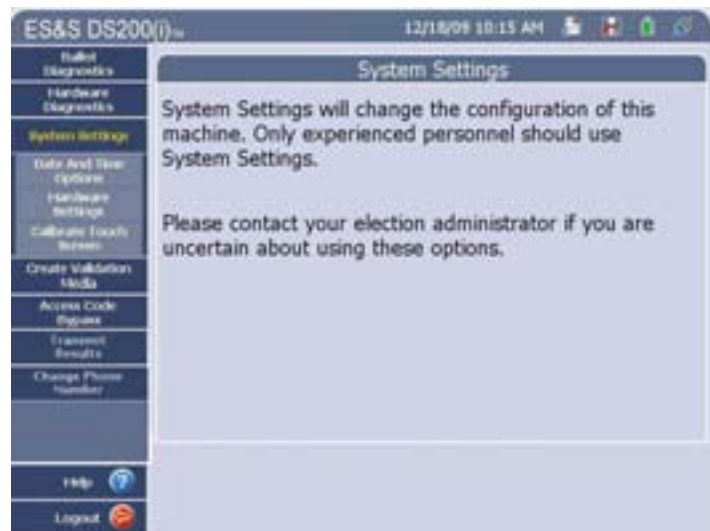

2. Press **Calibrate Touch Screen**. The Calibrate Touch Screen will appear.
3. Press **Continue**.

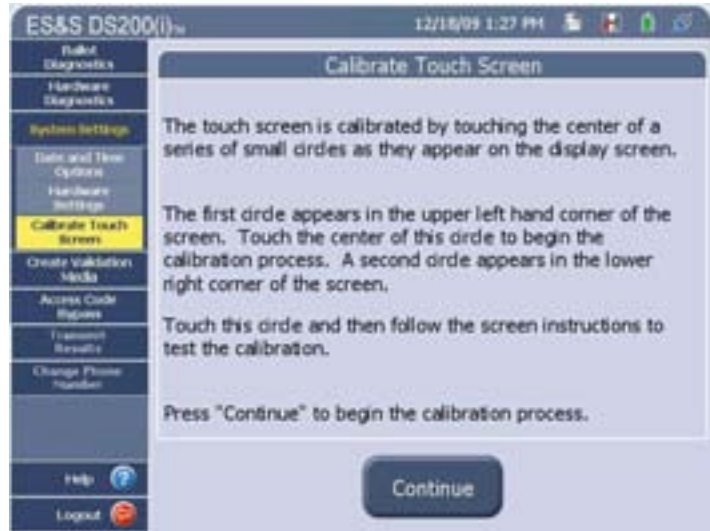

The following screen will appear.

4. Press the circle in the upper-left corner of the screen
5. Press the circle in the lower-right corner of the screen. The following screen will appear.

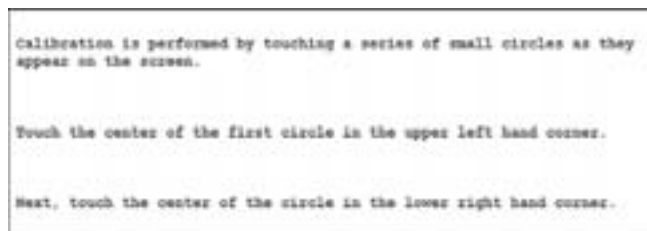
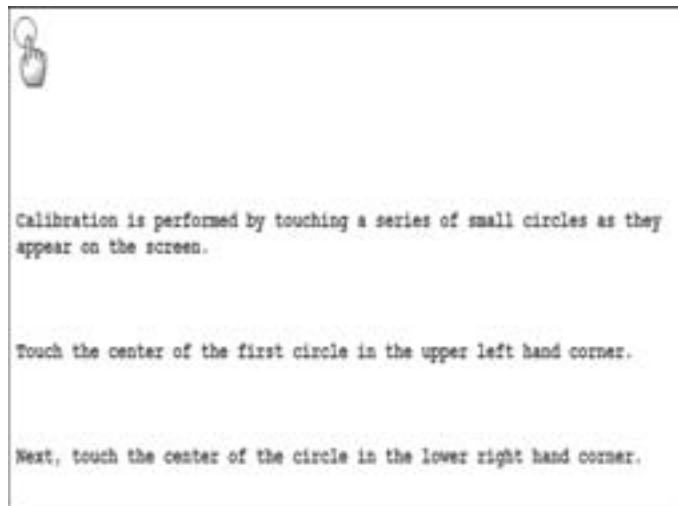

6. Test the calibration by touching the screen and see if the pointer will follow your touch points.
7. After you have finished testing the calibration, press **Save & Exit** to save your changes. If you need to recalibrate the scanner, press **Recalibrate**.
- 8.



Note: If you do not press either button within 30 seconds, the screen that appeared in Step 3 will appear and you will have to repeat steps 3 through 6.

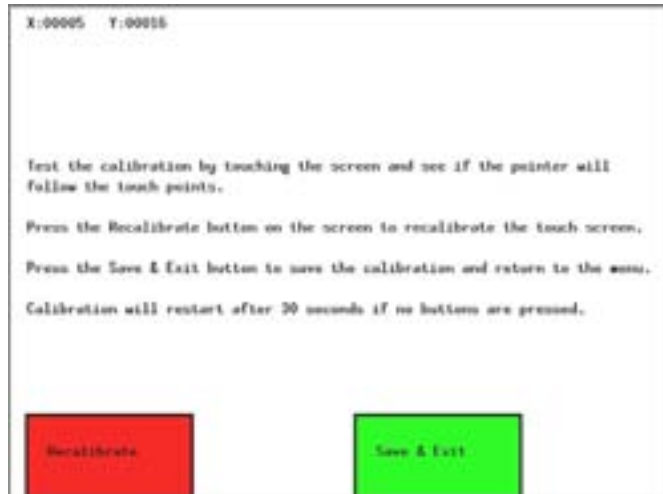

9. Once you press **Save & Exit**, a confirmation screen appears.
10. Press **OK**.

Test the Thermal Printer

Before you open the polls, test the thermal printer to see if your printer paper is installed correctly.

1. Take the paper that is sticking out of the DS200 and fold it over to your left.
2. Scratch the paper. If a grey mark appears, the paper is loaded correctly. If a grey mark does not appear, open the printer door and place the paper in the printer so the thermal (the side where the grey mark appears) is facing the printer rollers.

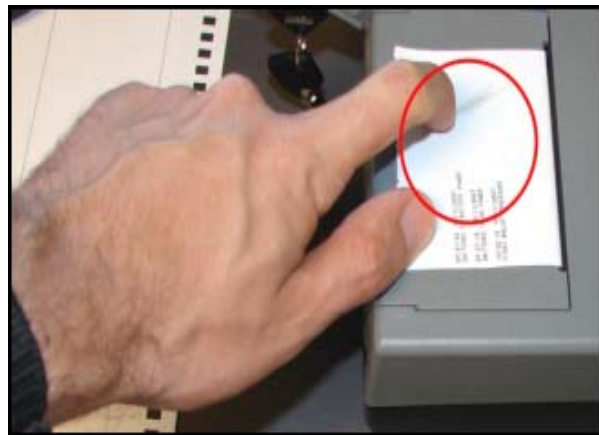

Pre-Voting Checklist

Review the following list before you open the scanner for voting:

- Have you anticipated all potential special voting conditions, such as overvotes and absentees, and included those conditions in the election definition?
- Have you charged the scanner's back-up battery?
- Is there a sufficient paper supply for the printer? Is a backup paper roll readily available?
- Have you properly completed setup and test procedures?

After completing all pre-election preparations, press **Shutdown** to turn off the DS200. Once the DS200 is turned off, unplug the DS200. Lock all access panels and prepare the scanner for transportation to the polling place.

Optional Step: Configuring the DS200 to Not Require a Security Code to Enter Voting Mode

Some jurisdictions want their poll workers to only have to lift the DS200's lid to open the polls, bypassing entering any security codes. You can configure the DS200 to do this by opening the units at the warehouse with the security code, shutting them down and then locking them.

Follow the steps below to configure a DS200 to bypass the security code entry screens when poll workers open the unit:

1. From the Administration menu, press **Access Code Bypass**. The **Access Code Bypass** screen appears.

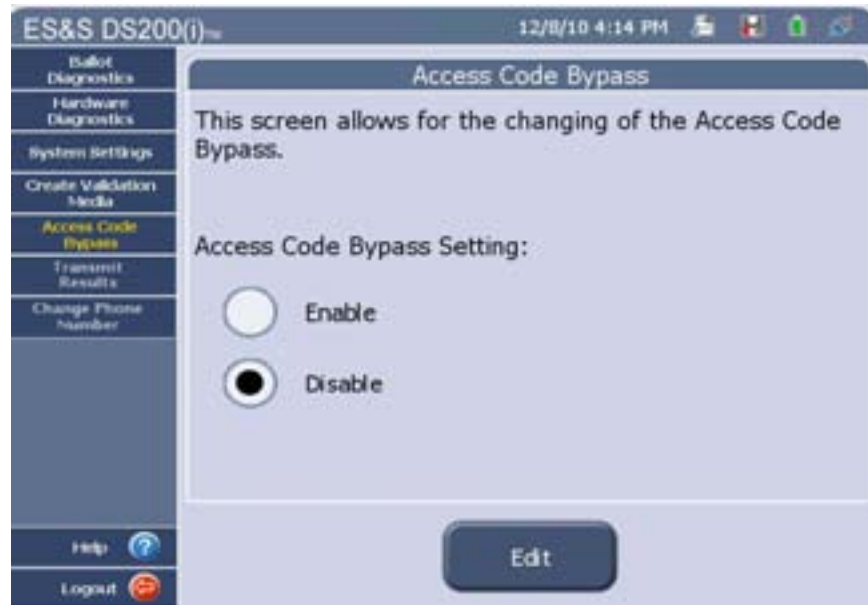

2. Press **Edit** and then select the **Enable** radio button.
3. Press **Apply**



4. A “Success” message appears if there are no issues.

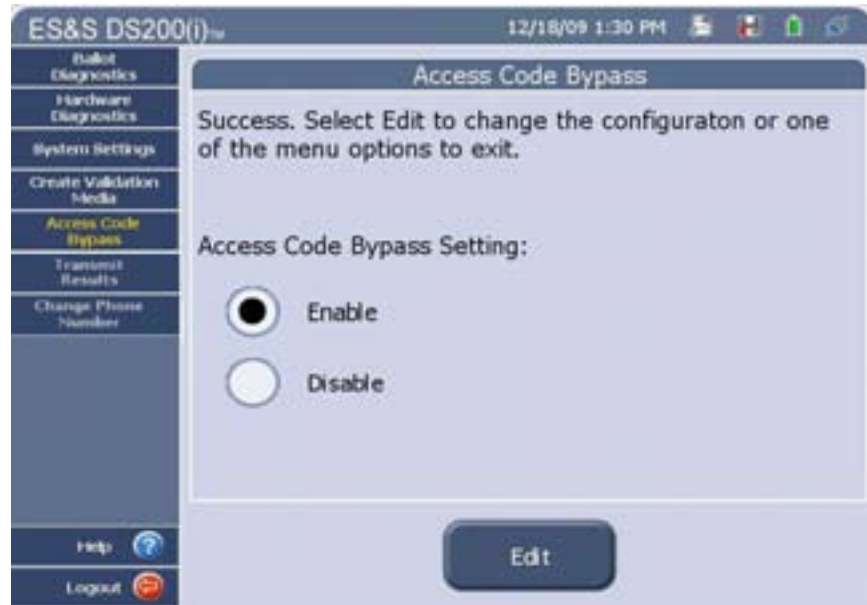

Optional Step: Create Media to Validate Firmware

Some jurisdictions require that the firmware loaded onto the DS200 be validated prior to deploying the machines in an election.

Follow the steps below to create the Validation Media which is used validate the contents of the CF card.

1. From the Administration menu, press **Create Validation Media**. The **Create Validation Media** screen appears. Insert a blank USB flash drive to use as a validation device into the backup USB port. Press **OK**.

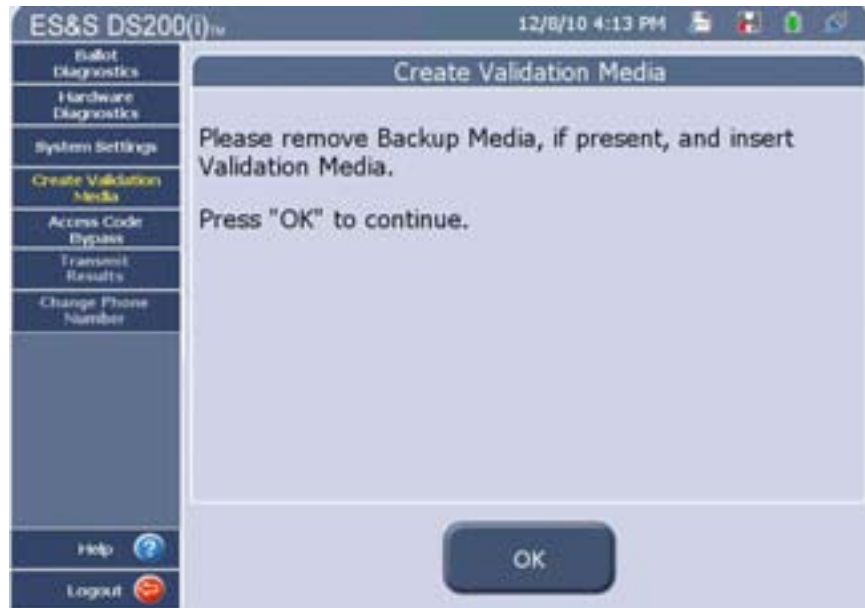

2. A message appears verifying that the Validation Media was created and that you can remove the media from the DS200.

Chapter 5: Election Day Tasks

This chapter contains instructions for the following Election Day tasks:

- ❖ **Open the Polls**
- ❖ **Write-in Votes**
- ❖ **Using the Tools Menu**
- ❖ **Handling Uncounted Ballots**
- ❖ **Close the Polls**
- ❖ **Reopen the Polls Without Clearing Vote Totals**
- ❖ **Reopen the Poll and Clear Vote Totals**
- ❖ **Print Election Reports**
- ❖ **Transfer Results**
- ❖ **Remove the Scanner From the Ballot Box**

Open the Polls

Before your polling location opens for voting, retest and check the system configuration for each of your scanners.



Reference: For more information about testing and configuring scanners, see [Chapter 4: Pre-Election Day Tasks](#).

Important: After you have run your test election, closed the polls, and the DS200 has printed all reports, you should follow one of the options below to ensure that test data remains segregated from election data:



- 1) Remove the USB Memory Device containing the test data, save the test election results, and insert a replacement USB Memory Device that contains the live election data.
- 2) Leave the USB Memory Device containing the test data in the DS200, you can then press Re-Open and the DS200 will allow you to select Clear Votes, to clear all the test data.

After you have inserted the USB Backup Memory Device (if one is required), configured, tested, loaded the election definition and turned on the DS200 scanner. Use the following instructions to prepare the scanners for voting.



Note: You can configure the DS200s so that poll workers do not need to enter a security code to open the polls. See [Optional Step: Configuring the DS200 to Not Require a Security Code to Enter Voting Mode](#) for additional information.

 **Note:** Upon inserting the Poll Media, the DS200 will validate the Backup USB stick's Qualification code. The DS200 validates both the poll media and backup, if a backup is used. If the Qualification code is validated the Poll Open process continues.

1. After you start the scanner you will need to your Election code under **Enter Election Code** and press **Accept**.



 **Note:** If a USB Backup Memory Device is installed, verify that the Configuration Report displays a non-zero number next to the report entry: **“Backup Space Available.”**

2. After the Election code is accepted and the election is validated the following screen appears. Press **Open Poll** to open the polls for voting.
3. Once you press **Open Poll**, the scanner performs the following functions:
 - The scanner checks available memory and scans the election definition for errors.

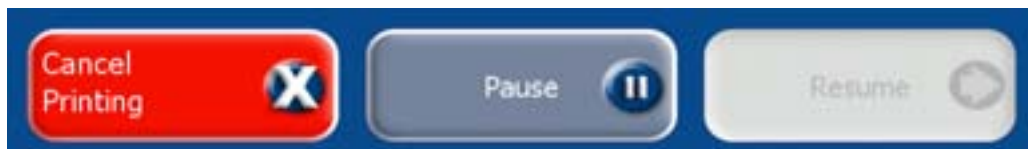

The DS200 prints the Ballot Status Accounting and Zero Reports. Press **Cancel Printing** at any time during printing to cancel the current report. Press **Pause** to pause the report printing. Press **Resume** to resume the report printing.

4. After the DS200 finishes printing the startup reports, the following screen appears.
5. If necessary, press **Report Options** to access the reports screen to print additional reports. If you need to print additional reports, skip to the [Report Options](#) section below.
6. Press **Go to Voting Mode**, when the scanner is ready for voting.
7. Close and lock the access panel. After you remove the key, the DS200 scanner is ready for live voting. Make sure that the public counter on the DS200 display screen increases by one with each ballot cast, but do not make any further adjustments to the scanner unless a system message appears.

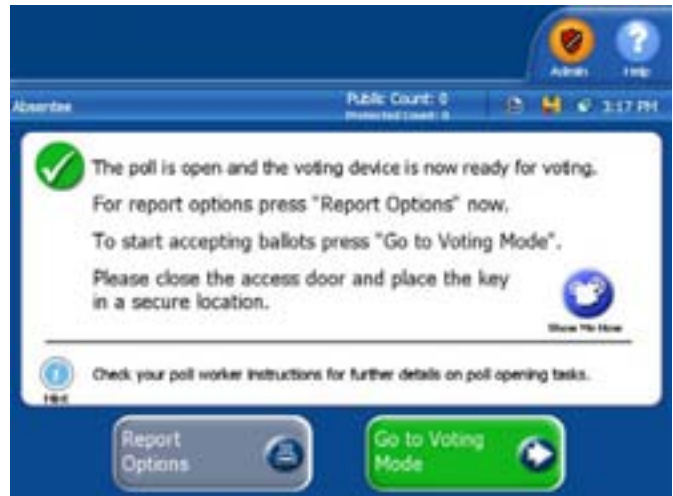

Report Options

From the Reports screen, you can print the following reports:

- Press **Ballot Status Accounting Report** to reprint your ballot status accounting report.
 - Press **Zero Report** to reprint your zero report.
 - Press **Event Log Report** to print an audit log of the activity that has occurred on the scanner. Information such as the date and times when the system is initialized and when it prints reports appears on this report.
 - Press **Configuration Report** to print a system configuration report. Information such as election settings, diverter settings and firmware version appears on this report.
- ❖ Press **Preview Report** to view a previewed copy of the report on the screen.
 - ❖ Press **Print** to print a hard copy of the report.

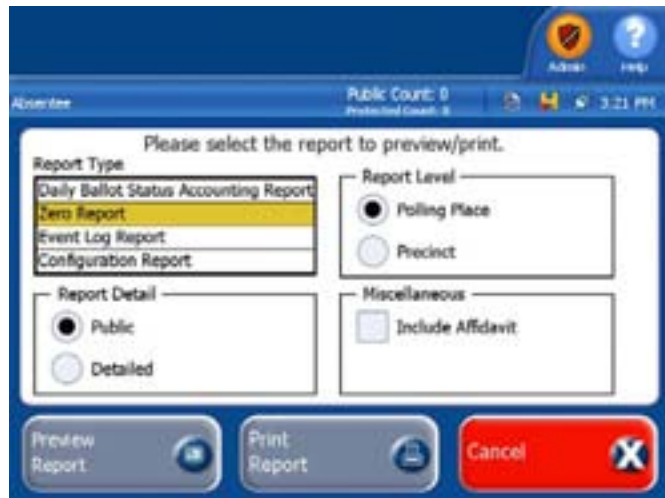

Voting

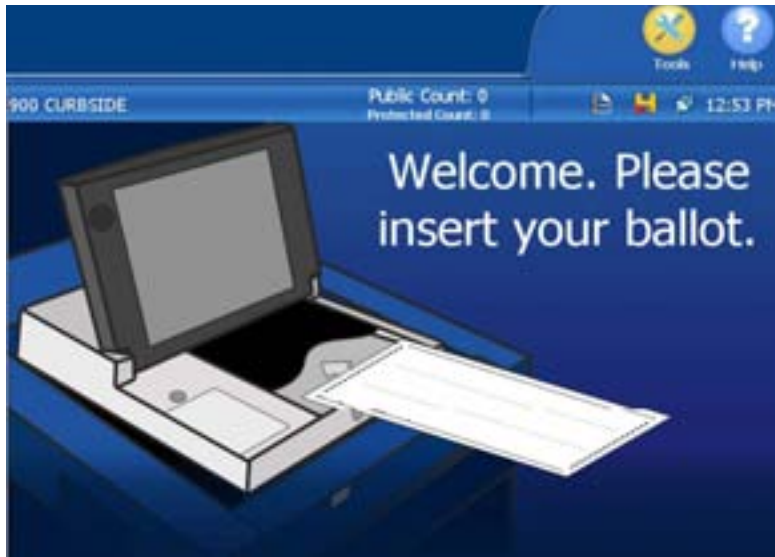

Arrange voting booths with the following considerations: traffic flow, voter privacy, safety and accessibility.

Voters will mark their ballots and if applicable, enter their write-in entries in private voting booths. Once a voter has marked a ballot, he or she will place the ballot into the DS200.

The DS200 also has the capability to collect individual graphical ballot images of all ballots. Depending on the options set in ElectionWare, it will collect all ballot images, only those containing write-in votes, or none at all. These ballot images are stored with random names and timestamps assigned to each file to protect voter anonymity.

In addition, the DS200 does not divulge any information identifying how a voter marked a ballot when the ballot is cast. The only visible change in system status after a voter casts a ballot is the visible addition to the public count.



Note: The DS200 ballot bin main storage area was designed to hold approximately 2,500 pieces of paper.



Note: The DS200 emergency ballot bin was designed to hold approximately 100 pieces of paper. This number will need to be divided by the number of pages per ballot to estimate the ballot capacity of the emergency bin.

Overvoting Warnings



Important: If **Always Accept** is selected in the **Overvoted Ballot** field in the DS200 settings in ElectionWare, the Over Voted Ballot screen will not appear.

If **Always Reject** is selected in the DS200 settings in ElectionWare, the ballot will not be able to be processed until all mistakes are resolved.



Reference: For more information about the DS200 settings, refer to the *ElectionWare System Operations Procedures* manual.

If a voter exceeds the number of votes allowed for a contest, the following screen appears.

The contest(s) containing overvotes appears below the **Contest Title** column. If there are several overvoted selections, the **Next** and **Back** buttons will appear below the contest titles. If necessary, press the **Next** and **Back** buttons to review your overvoted selections. Two options are available:

- ❖ Press **Correct Your Ballot** to return the ballot to the voter. The voter may then ask for a new ballot from a poll worker and remark the ballot.
- ❖ Press **Cast Your Ballot with Mistakes** to cast the ballot without making any changes.



Overvote and Undervote Warnings

If a voter has both undervoted and overvoted mistakes on their ballot, the Possible Mistakes on Ballot screen appears.

This type of ballot mistakes (for example overvote) appears under the **Mistake Type** column. The number of contests containing the ballot mistakes appears under the **Number of Contests** column.

1. Press **Review Mistakes**. The Over Voted Ballot screen appears or press **Correct Your Ballot** to return the ballot to the voter. The voter can then request a new ballot from a poll worker.

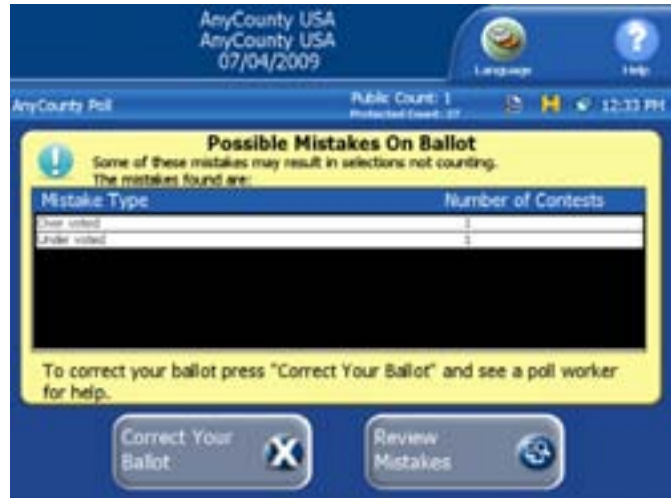

2. Once the voter has reviewed the overvoted mistakes on the screen, he or she can make the following selections:
 - Press **Correct Your Ballot** to return the ballot to the voter. The voter can then request a new ballot from a poll worker.
 - Press **Next** to view the list of under voted mistakes.

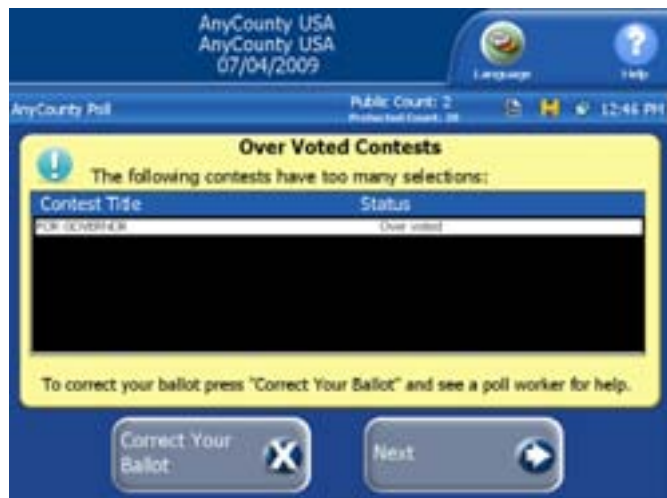

3. Once the voter has reviewed the undervoted mistakes on the screen, he or she can make the following selections:

- Press **Correct Your Ballot** to return the ballot to the voter. The voter can then request a new ballot from a poll worker.
- Press **Finish Review** to go to the Possible Mistakes on Ballots screen.

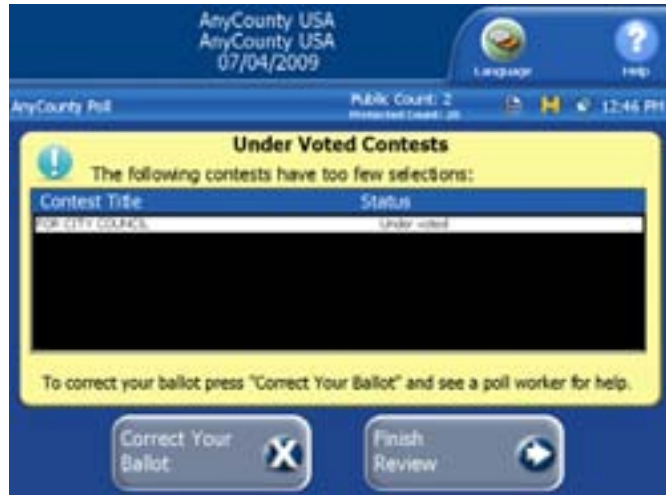

4. From the Possible Mistakes on Ballot screen, the voter can make the following selections:

- Press **Correct Your Ballot** to return the ballot to the voter. The voter can then request a new ballot from a poll worker.
- Press **Cast Your Ballot with Mistakes** to cast the ballot without making any changes.



Unreadable Marks

If the ballot has marginal or incomplete marks, the DS200 can be setup to identify these ballots.



If **Always Accept** is selected in the **Unreadable Marks on Ballot** field in the in the DS200 settings in ElectionWare, the **Unreadable Marks on Ballot** screen will not appear.

If **Always Reject** is selected in the DS200 settings in ElectionWare, the ballot will not be able to be processed until all mistakes are resolved.



Reference: For more information about the Set Tabulator Parameters window in ElectionWare, refer to the Tabulator Settings heading in Chapter 5: Generate Elections in the *ElectionWare System Operations Procedures* manual.

1. The contest(s) containing incomplete marks appears below the **Contest Title** column.
 - Press **Correct Your Ballot** to return the ballot to the voter. The voter can then request a new ballot from a poll worker.
 - Press **Review Mistakes** to review the mistakes on the ballot. This will bring up the Unreadable Marks screen.

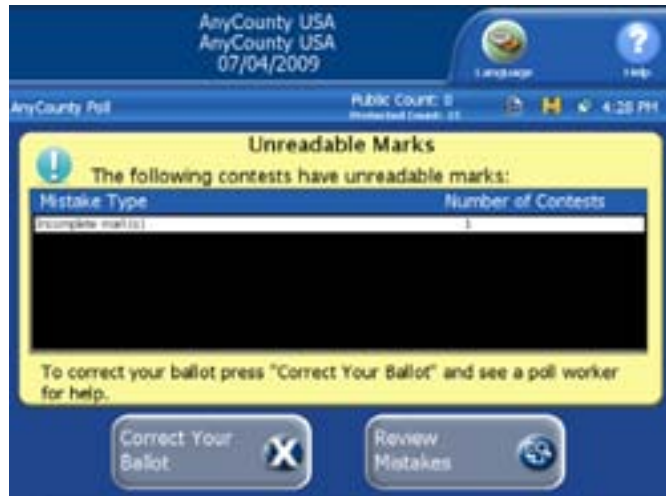

2. On the Unreadable Marks review screen the contest(s) containing the unreadable marks appears below the Contest Title column. If there are several unreadable marks, the **Next** and **Back** buttons will appear below the contest titles. If necessary, press the **Next** and **Back** buttons to review your undervoted selections.
 - Press **Correct Your Ballot** to return the ballot to the voter. The voter can then request a new ballot from a poll worker.
 - Press **Cast Your Ballot with Mistakes** to cast the ballot without making any changes.



Blank Ballots

If the ballot is blank, the DS200 can be setup to identify these ballots.

- Press **Correct Your Ballot** to return the ballot to the voter. The voter then can review and mark the ballot.
- Press **Cast Blank Ballot** to cast the ballot without making any changes.

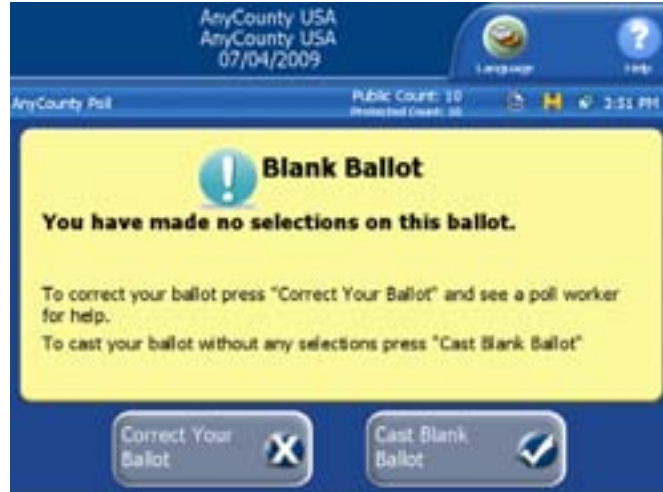

Important: If **Always Accept** is selected in the **Blank Ballot** field in the in the DS200 settings in ElectionWare, the **Blank Ballot** screen will not appear.



If **Always Reject** is selected in n the DS200 settings in ElectionWare, the ballot will not be able to be processed until all mistakes are resolved.





Reference: For more information about the Set Tabulator Parameters window in ElectionWare, refer to the Tabulator Settings heading in Chapter 5: Generate Elections in the *ElectionWare System Operations Procedures* manual.

Multi-Language Voting

From the Welcome screen, voters can select any of the languages presented on the Welcome screen. The DS200 supports the following ballot languages:

- English
- Spanish
- Chinese
- Korean
- Japanese

Examples of foreign language Welcome Screens include:

	Spanish
	Korean
	Chinese

Once a voter or poll worker selects a language, the ballot insertion screen will appear in the selected language.

Precincts with more than four languages will display left and right arrows to scroll through the list of languages.

Ballot Insertion Screen with more than four languages



Ballot Insertion Screen in Korean



Ballot Insertion Screen in Spanish



Ballot Insertion Screen in Chinese



Write-in Votes

If a ballot contains write-in entries, the DS200 will stamp a pink circle on the ballot, if the option was set in ElectionWare. The stamp will appear on the side of the ballot you placed face down on the scanner, in the center, at the trailing edge of the ballot. The following is an example of a ballot showing the write-in entries section. (This ballot was scanned front side down, top first.)



Deliver all write-in ballots to your election administrator as soon as possible after the polls close. Separate all of the write-in ballots from regular ballots. To remove write-in ballots from the ballot box, follow the instructions under the [Closing and Removing the DS200 Tote Bin from the Plastic Ballot Box](#) heading of this chapter.

Assist ADA Voters

Poll workers may be required to assist ADA (Americans with Disabilities Act) voters with using the DS200. For example, a poll worker may be asked by the voter to insert their ballot into the DS200, correct ballot handling exceptions (e.g. undervotes, overvotes, mistakes), or assist with casting a ballot after exceptions have been resolved or accepted by the ADA voter who is unable to interact with the DS200's interface.



Note: AutoMark users can eject their ballot into a privacy sleeve, which can then be transported by the voter or assisting poll worker to the DS200 and inserted into the scanner. If there are no ballot handling exceptions, the DS200 deposits the ballot in the ballot box. If there are exceptions, the poll worker must confirm with the voter that the ballot is to be cast as is. For additional information about the assistance that the poll worker may be requested to provide, as well as the use of a privacy sleeve by the voter, see the *ES&S AutoMARK System Operations Procedures* manual.

Precinct Selection During an Early Voting Period

The following process allows users to select a precinct when scanning their ballot.



Note: This process is primarily for precinct based, early voting sessions at a voting location conducting a By-Style election. The DS200 MUST have polls opened and be ready for ballot scanning.

1. Insert your ballot into the DS200

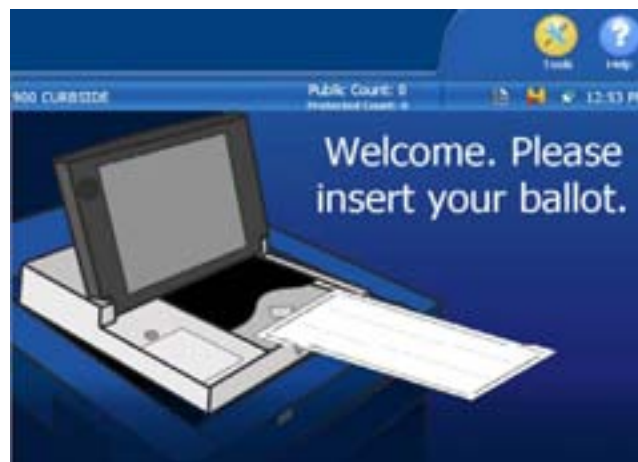

2. An authentication prompt appears; enter your pass code.
3. The DS200 prompts you to enter a precinct name; enter your precinct and select **Continue**. You can also search for the precinct.
4. The DS200 displays the matching precinct; select the precinct if it is valid.

5. The DS200 displays the precinct for confirmation; select the confirmation that the precinct is correct.
6. The DS200 accepts the ballot and resumes normal scanning and tabulation functions until the “Thank You for Voting” screen appears.

Using the Tools Menu

1. Press **Tools**, to enter the menu.

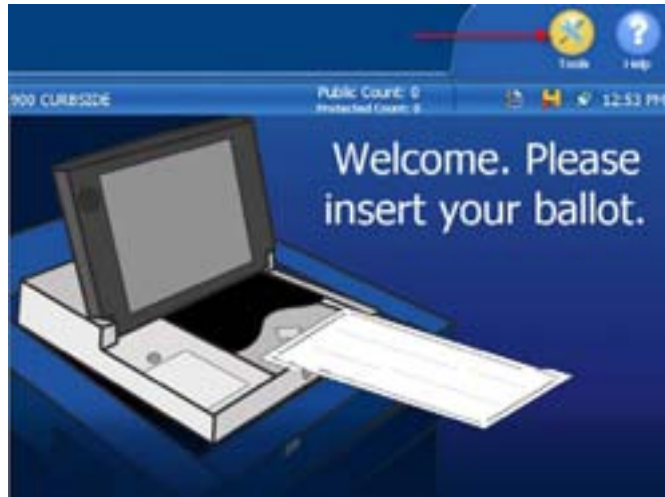

2. The Enter Election Code code screen appears. You will need to enter your code, then press **Accept**.



The following options will be displayed:

- **Override Ballot Rejection** - used to process ballot that are rejected due to an exception on the ballot.
- **Report Options** - used to view and print reports.

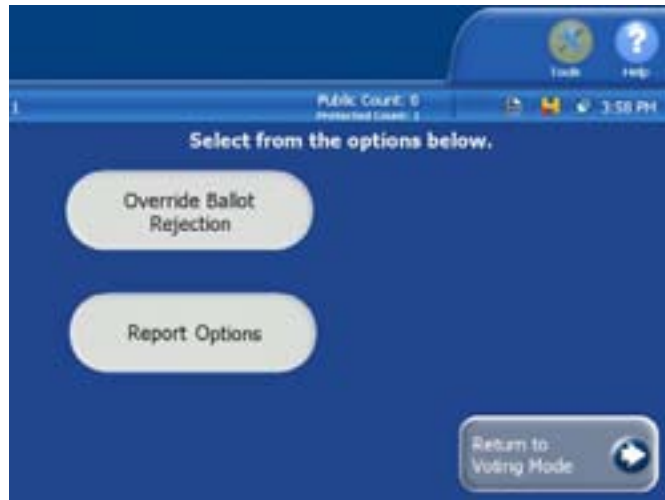

Override Ballot Rejection

This option is used to process ballots that may be rejected due to an exception on the ballot, if the option was set in ElectionWare to reject the improperly marked ballots.

1. From the Tools Menu, touch **Override Ballot Rejection**.
2. Select from the following options;
 - **Override One Ballot** - allows the poll worker to process one ballot with exceptions.
 - **Override All Ballots** - allows the poll worker to process multiple ballots with exceptions.
3. Select **Yes** to accept the ballot with the exceptions on the ballot, select **No** to exit the screen.
4. If you selected **Yes** you will need to insert the ballot into the scanner.
 - If you selected to Override One Ballot after the ballot has been scanned you will be returned to the Welcome Screen.
 - If you selected Override All Ballots once the ballot is scanned, you will have the options to continue scanning ballots. Once you are done scanning all the ballots, select **Exit** to go back to the previous screen. Then select **Menu** to go back to the Tools Menu and select **Return to Voting Mode** to return to the Welcome Screen.

Report Options

1. In the Tools Menu select **Report Options**.
2. Select the report you would like to print:
 - Daily Ballot Status Report
 - Zero Totals
 - Event Log Summary
 - Event Log
 - Configuration
 - System Log
3. You can select to preview the report by selecting **Preview Report**, select **Print Report** to print the report or select **Cancel** to exit the menu.

Handling Uncounted Ballots



Note: To insert the new Tote Bin, see [Preparing the DS200 Ballot Box to receive the Tote Bin](#)

Store any ballots that were not counted during voting due to power failure or scanner problems in the emergency ballot bin.



Important: Confirm your jurisdiction's regulations for handling uncounted ballots before you remove and scan stored ballots.

Unlock the emergency ballot bin panel to remove uncounted ballots. Before you close the polls, remove and scan the uncounted ballots to add the totals to your scanner's memory.

Metal Ballot Box

Emergency Ballot Bin

1. Unlock the bottom lock on the front of the metal ballot box.
2. Swing the hinged door on the front of the box down to access the emergency ballot bin.
3. Inspect the uncounted ballots for damage and then feed them into the scanner.



Important: Double-check the back of the bin to make sure that no ballots remain uncounted.

Plastic Ballot Box

1. Unlock the door to the emergency ballot bin on the front of the ballot box.
2. Swing open the door to access the ballots.
3. Inspect the uncounted ballots for damage and then feed them into the scanner.

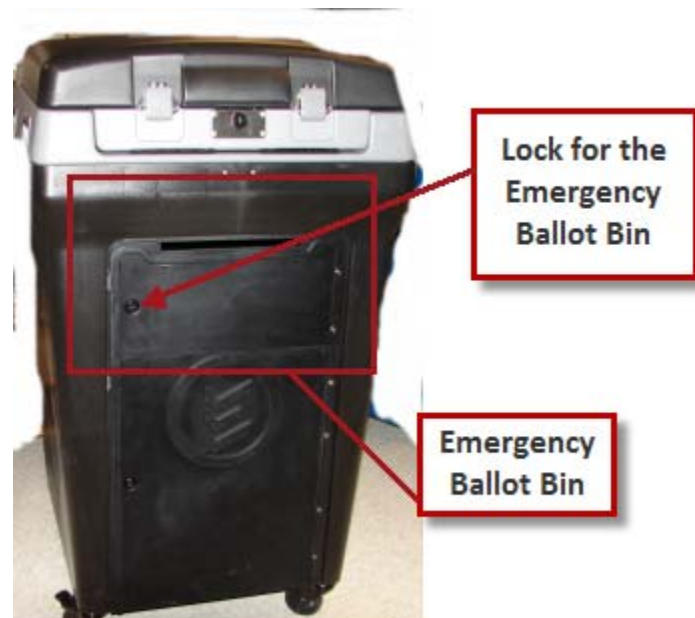

Important: Double-check the back of the bin to make sure that no ballots remain uncounted.

Close the Polls

Close your polling place for voting at the assigned time and then, use the DS200 control key to prepare scanner results for processing. You cannot print reports or process vote totals from the scanner's USB flash drive until you properly close the polls.

You can print election, event, and audit log reports after you close the scanner for voting.

1. Check the emergency ballot storage bin for uncounted ballots.



Note: Study your jurisdiction's procedures for handling uncounted ballots before Election Day.



Reference: For more information about removing and processing sorted ballots, see [Handling Uncounted Ballots](#) in this chapter.

2. Unlock the DS200 access door.
3. Press the **CLOSE POLLS** button, located above the power button.
4. Press **Don't Close - Keep Voting** if you do not want to close the polls and continue voting. Press **Close Poll** to close the polls.

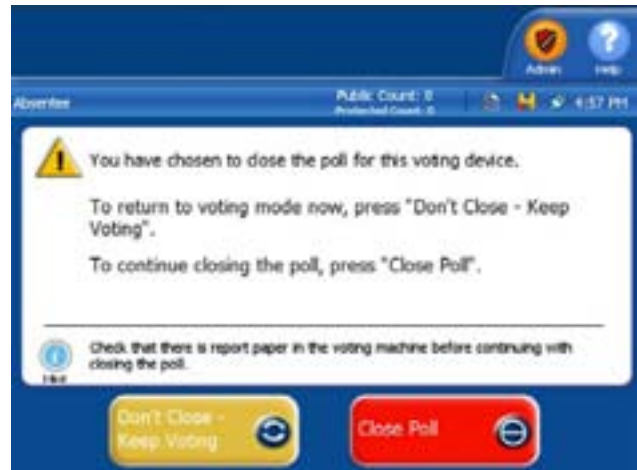

Depending on your election configuration in ElectionWare, the scanner may automatically print one or more of the following reports: Ballot Status Accounting Report, Results report, Configuration Report and/or Audit Log report.

- While the report is printing you will have the option to:

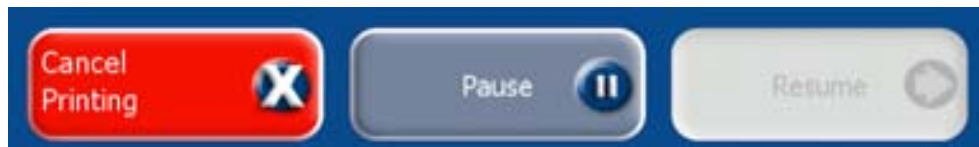

- Press **Cancel Printing** to stop printing the report that is currently printing.
 - Press **Pause** to pause the report that is currently printing.
 - Press **Resume** to resume printing a report that was previously paused.
5. Upon a successful poll close, the DS200 writes the following information to the USB Backup Memory Device if a backup device is in use:

- A copy of every file on the Election Media (including the encrypted machine specific key).
- A copy of the Poll Media's eba.hdr file with the type 'BACKUP' rather than 'ELECTION.'
- A new eba.hdr.asc file.



Reference: Refer to the *ElectionWare System Operations and Procedures* manual for more information about configuring your election.

When the scanner has finished printing reports, the following screen will appear.



If necessary, press **Report Options** to reprint any additional reports.

6. Press **Finished - Turn Off**.
7. Once the **Power** button light is off, remove the USB flash drives from the DS200.
8. Follow your jurisdictions guidelines for securing and delivering the USB flash drive to the Election Headquarters.



NOTE: If the ERM Key Media is misplaced or damaged, the USB Backup Memory Device may be used to collect totals in ERM.

Emergency Procedure to Shutdown the DS200

Follow the steps below to shut down the DS200 in case of an emergency, such as vandalism or civil disobedience:

1. Press and hold down the **Close Polls** button.
2. Press on **Admin** in the top right-hand section of the screen.
3. Press **Shutdown** on the Admin menu.

Reopen the Polls Without Clearing Vote Totals

If you discover voted ballots mistakenly left in voting booths or in the emergency ballot storage bin after the polls close or, if you must close the scanner for voting before the assigned time, you can reopen the DS200 to scan uncounted ballots. The additional ballots will be added to the totals.

Any poll re-open, whether clearing votes or not, requires the re-initialization of the USB Backup Memory Device by the DS200 if a backup memory device is in use.



Note: Some jurisdictions do not allow reopening of the polls after the assigned closing time. Your jurisdiction must specifically request the option to reopen the polls from ES&S election programmers or include the option on the election definition USB flash drive in order to reopen polls.

1. If the DS200 scanner is turned off, use the key to open the access door. If you removed the USB flash drive, reinsert the USB flash drive and turn on the DS200.
2. The Enter Election Code screen appears. You will need to enter your code. Then press **Accept**.



After the Configuration Report prints, the Poll Closed screen appears.

3. Press **Re-open Poll**.



The Enter Override Code screen appears.

4. Enter the code assigned to reopen the polls. If you do not have the code, contact your election administrator or ES&S customer support for the scanner security code.
5. Press **Accept**.



The following screen appears.

6. Press **Re-Open Poll**.

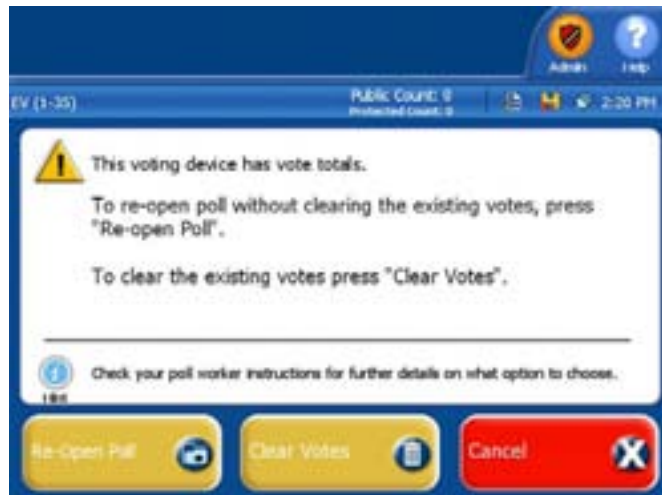

The following screen appears.

7. If necessary, press **Report Options** to access the reports screen to print additional reports. If you need to print additional reports, skip to the [Report Options](#) section below.
8. Press **Cancel** when you are finished printing reports.
9. Press **Go to Voting Mode**.

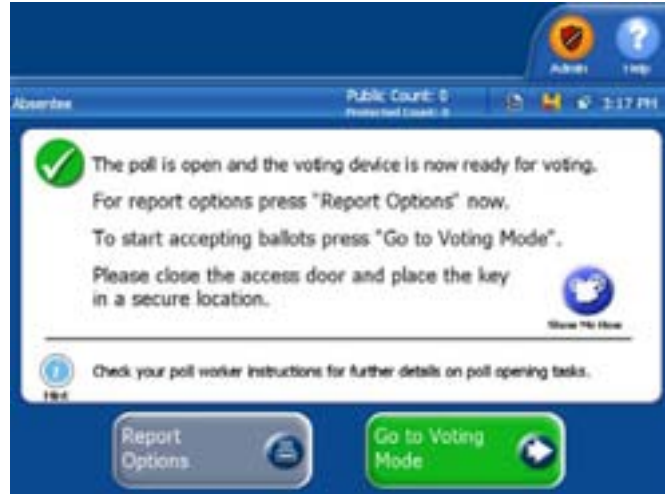

10. Close and lock the access panel. After you remove the key, the DS200 scanner is ready for live voting. Make sure that the public counter on the DS200 display screen increases by one with each ballot cast but do not make any further adjustments to the scanner unless a system message appears.

Upon successfully re-opening the polls, if a backup media is in use, the DS200 will re-initialize the Backup Memory Device. The Backup Memory Device is then reformatted by the DS200, erasing all existing information. Upon successfully reformatting the Backup Memory Device, the appropriate files will be written to the Backup Memory Device.

11. Resume scanning ballots.

Reopen the Poll and Clear Vote Totals

If you choose to reopen the polls and clear voting totals, you will need to rescan all ballots that have been cast on that machine.



Note: Some jurisdictions do not allow reopening of the polls after the assigned closing time. Your jurisdiction must specifically request the option to reopen the polls from ES&S election programmers or include the option on the election definition USB flash drive in order to reopen polls.

1. If the DS200 scanner is turned off, use the key to open the access door. If you removed the USB flash drive, reinsert the USB flash drive and turn on the DS200.

2. The Enter Election Code code screen appears. You will need to enter your code. Then press **Accept**.



After the Configuration Report prints, the Poll Closed screen appears.

3. Press **Re-open Poll**.

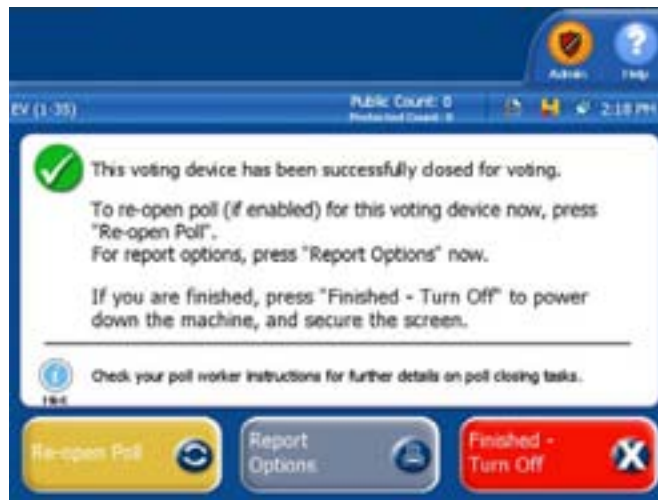

The Enter Override Code screen appears.

4. Enter the code assigned to reopen the polls. If you do not have the code, contact your election administrator or ES&S customer support for the code.
5. Press **Accept**.



The following screen appears.

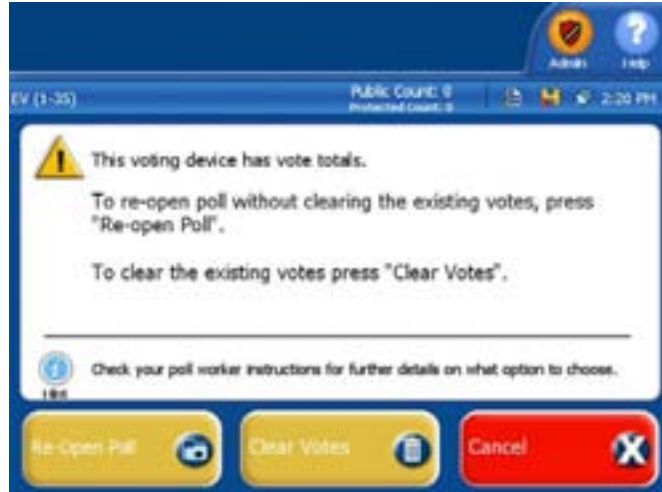

- 6. Press **Clear Votes**. The following screen appears.

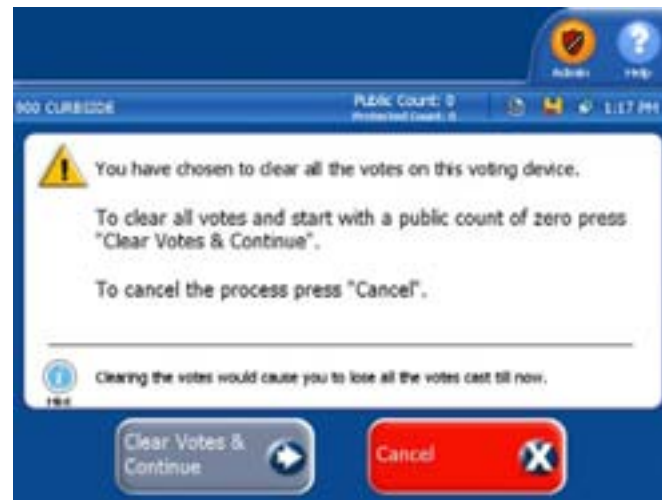

- 7. Press **Clear Votes & Continue**. The Clear Votes screen appears.

The following screen appears if the clear votes process is successful.

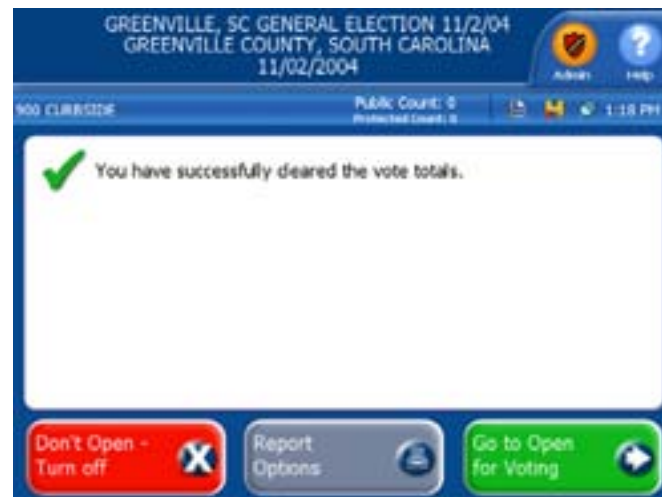

- 8. Press **Go to Open for Voting** if you want to proceed with opening the polls. Press **Report Options** if you want to view the available reports or press **Don't Open Turn Off** to shut down the scanner.

The following screen appears when you press on **Go to Open for Voting**

9. Press **Open Poll** to open the Polls.

The Ballot Status Accounting Report and Zero Reports are generated.



10. The Poll is ready to be opened. The following screen appears notifying you that the polls are open and ready for voting.

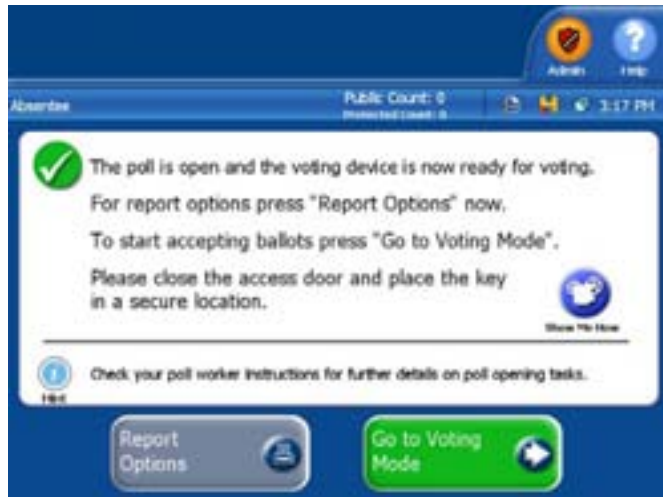

11. Press **Go to Voting Mode**. The following welcome screen appears.

12. Close and lock the access panel. After you remove the key, the DS200 scanner is ready for live voting. Make sure that the public counter on the DS200 display screen increases by one with each ballot cast but do not make any further adjustments to the scanner unless a system message appears

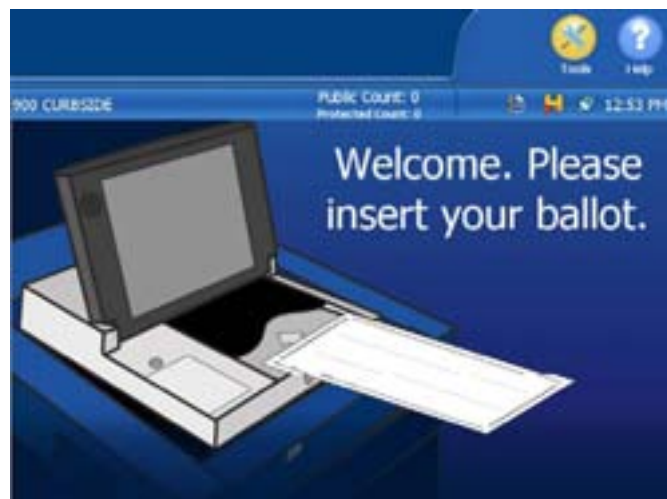

13. Resume scanning ballots.

Closing and Removing the DS200 Tote Bin from the Plastic Ballot Box

1. Once the Counted Ballot Capacity has reached approximately 1500 ballots, the Tote Bin has to be changed out. Remove the seal from the Lower Bin Door and record the number.

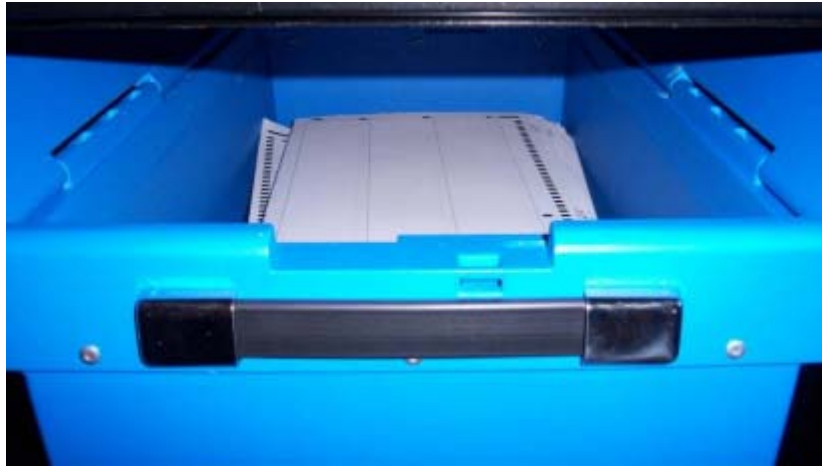

2. The Tote Bin must be closed before it is removed from the Lower Bin. The Lid Halves have an Inner and Outer Lip to them that mesh together and a metal lip. The bin is designed this way in order to prevent uncounted ballots from being slid between the Lid Halves. Close the Tote Bin by starting from the right side and then the left side, place the inner lip between the outer lip and metal lip, then close the lid.

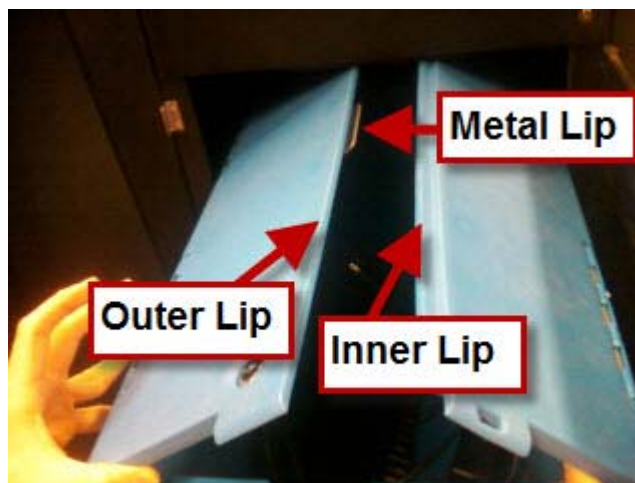

3. Once both lids are closed and while the Tote Bin is still inside the Lower Bin, reach inside the Lower Bin and lock the Top Front Lock.



4. Using the Strap Handle on the Tote Bin, pull the Tote Bin out enough to leave the backside still in the Lower Bin.



Caution: Do not pull the Tote Bin out completely as this will drop the backside onto the ground. This action could result in cracking and/or breaking the back Tote wheels.



Caution: Do not deploy the Telescoping Handle as this could result in bending of the Handle to where it would not retract correctly.

5. Once the backside of the Tote Bin has been exposed, lock the Top Back Lock.

6. After both locks have been locked, apply a seal to both sides.

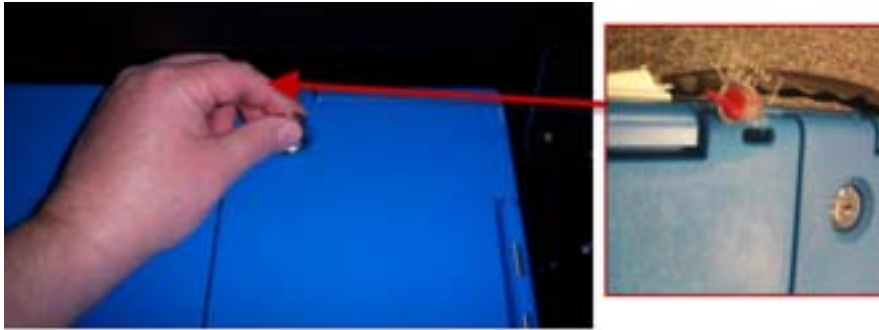

7. Lift the Tote Bin out of the Lower Bin by grasping the Strap Handle and the lip on the backside of the Tote Bin.

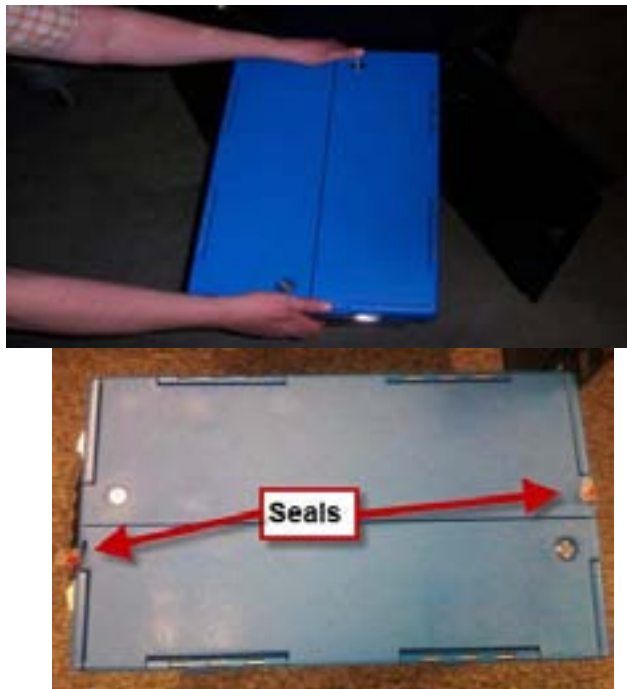

8. While grasping the Strap Handle, tilt the Tote Bin back slightly so that the Telescoping Handle can be deployed.



Remove Ballots from the Metal Ballot Box



Caution: Follow your jurisdictions guidelines for removing ballots from the ballot bin. Contact your election official for any questions.

1. Unlock and open the door on the front of the metal box to gain access to the ballots.
2. Remove and store the ballots per your jurisdictions guidelines. This includes ballots that were diverted for additional review (exp. write-ins).

Print Election Reports

The DS200 generates a variety of results reports after the polls close. Depending on the options configured for your election definition, the scanner may automatically print reports when you close the polls or you can manually select reports from the POLLS CLOSED screen.

1. Close the polls to access the POLLS CLOSED screen and press **Report Options** to reprint any automatic reports generated when the polls are closed. The types of reports generated depend on your election definition settings.
2. To print additional reports, return to the POLLS CLOSED screen press **Report Options** select from one of the following report options:
 - Ballot Status Accounting
 - Zero Totals (Polling Place or Precinct) - Public or Detailed
 - Voting Results (Polling Place or Precinct) - Public or Detailed
 - Event Log Summary
 - Event Log
 - Configuration
 - System Log



Note: You can configure your election definition to require a code to access the report menus.



Reference: For descriptions and examples of each DS200 report, see [Chapter 7: Reports](#).

Transfer Results

If your jurisdiction uses Election Reporting Manager to generate election reports, transfer election results from your scanners to the PC running the reporting software.

1. Unlock the access door. Remove the USB flash drive from the scanner.
2. Follow your jurisdictions guidelines for securing and delivering the USB flash drive to the Election Headquarters.



Chapter 6: Post Election Day Tasks

Use the instructions in this chapter to perform the following task after you have run your election.

Note: ES&S recommends that the scanner be stored in the carrying case on top of the ballot bin.



Care should always be observed when moving the DS200, especially if attempting to move over uneven surfaces, stairs, ramps, etc. The lifting handles on the sides of the ballot box can be utilized to stabilize the entire unit while moving the ballot box.

If you need to remove the scanner with the carrying case or only the scanner. Please follow below instructions:

- **Remove the Scanner From the Ballot Box**
- **Remove the Scanner and Carrying Case from the Ballot Box**

Remove the Scanner From the Ballot Box

Use the instructions in this chapter to remove the scanner from the Plastic and Metal Ballot Box.

1. If the unit is still on, power down the scanner.
2. Close and lock the Key Access Panel and Printer Access Panel.
3. Unlock the top hinged panel on the front of the ballot box and swing it down to expose the front of the scanner.
4. Unplug the scanner from the wall outlet.



5. Pull the scanner forward about four to five inches and disconnect the power cord from the back of the terminal.



When disconnecting the power cord make sure to grab the collar and pull it back to release it from the scanner.



Caution: Do not attempt to force the power cord out, you must pull the collar back to release it from the scanner.



6. Thread the cord through the back of the ballot box.
7. Slide the scanner forward until it clears the mounting rails and remove the scanner from the ballot box.



8. Carefully pack the scanner and ballot box for storage.

Remove the Scanner and Carrying Case from the Ballot Box

1. Unplug the power cord from your power source.
2. Use the Velcro strap to tie the power cord.



3. Make sure the bar is in the locked position.



4. Neatly wrap the power cord into the back of the rear panel.
5. Close and lock the rear panel of the case. Make sure the power cord does not get pinched in the door, otherwise it may not close properly.



6. Press down on the two tabs Lock the front of the carrying case.



7. Unlock the left and right sides of the carrying case from the ballot box.



8. Use the side bars on the carrying case to lift the carrying case off of the ballot box.



9. Carefully, place the DS200 on the ground, with the wheels placed on the ground.
10. Store the equipment following the guidelines set forth in this manual.



Note: The weight of the DS200 is about 25 pounds. The weight of the carrying case is about 10 pounds.



DS200 Lower Ballot Bin Storage

Follow these steps to properly stack DS200 lower ballot bins for storage.

1. Remove the E-Bin Assembly from the ballot box.
2. Position the casters so that the wheels are turned under the bin (see Figure 1). Use packaging material or a large rubber band to hold the wheels in place.



Figure 1

3. Stack the DS200 Ballot Bins so that the doors from one Ballot Bin are on the opposite side or 180 degrees from the previously stacked DS200 Ballot Bin (see Figure 2).

Figure 2

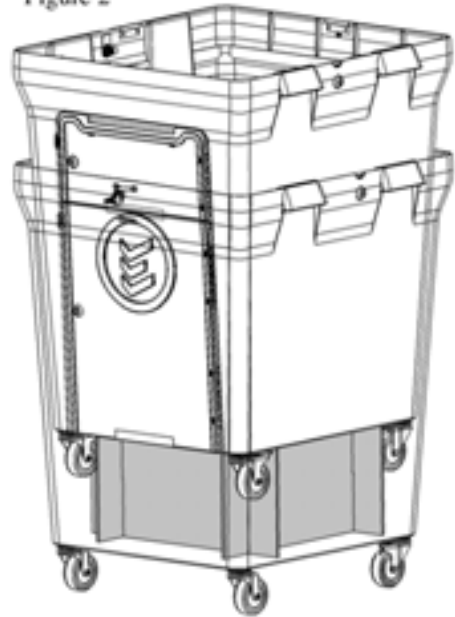

4. When stacking the Ballot Bins, lift the bin so that the casters clear the rim of the previous bin, move the bin over the previous bin, and lower the bin keeping the bin as vertical as possible (see Figure 3).
5. Stacked bins should be approximately ten (10) inches apart (top rim to top rim). Do not push down or press bins together. Stacking in this manner will compress the Ballot Bins and not allow for easy removal of the bins. Use materials such as the spacer packaging that was shipped with the DS200 Ballot Bins or other materials that will not compress, and that will keep the Bins approx. 10 inches apart; rim to rim.
6. If packaging is not available to space the DS200 Ballot Bins 10 inches apart, then only three (3) DS200 Ballot Bins can be stacked together. In this situation, follow Step 3. Note that the Ballot Bins are alternated 180 degrees so that the doors are opposite each other.

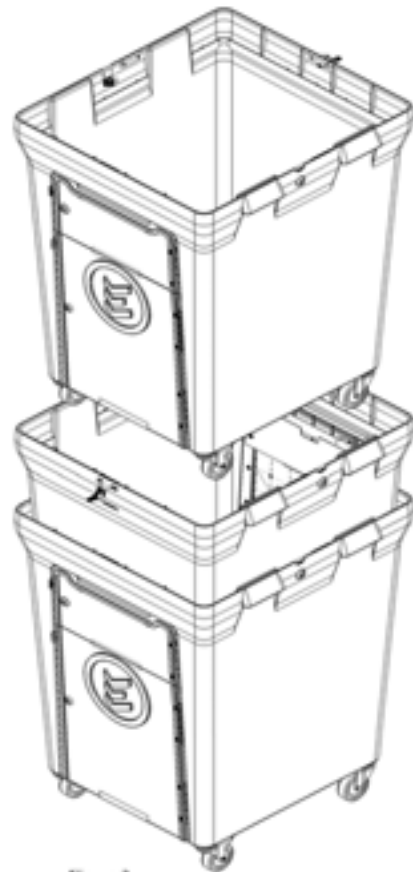

Figure 3

7. Stack the E-Bins together (taking care as not to damage the Ballot Diverter Metal Strips). Place the E-Bins inside the last stacked bin.
8. When un-stacking the DS200 Ballot Bins, reverse the steps followed to stack the Bins. Care must be taken when un-stacking the Bins as to not allow the casters of the stacked Bins to catch on the wire frame on the inside of the Ballot Bin to be un-stacked.

Part 3: DS200 Reports and Maintenance

Part 3 contains information about the following topics.

- ❖ [Chapter 7: Reports](#)
- ❖ [Chapter 8: Scanner Maintenance](#)

Chapter 7: Reports

The DS200 generates a variety of election results reports. This chapter contains descriptions and examples of each available report. Use the information in this chapter to become familiar with the report formats and types so that you can generate the proper reports for your jurisdiction.

Report Format

ES&S or your jurisdiction's election programmer hard codes available report formats into the DS200 election definition. The report formats that you select (either public or detailed) affect the Poll Reports and Precinct Reports generated directly from the DS200. Reports printed in public format display candidate names, candidate vote totals and write-in totals. Reports printed in detailed format display candidate names, candidate vote totals, write-in totals, undervote totals and overvote totals.

NOTE: When the DS200 prints a report, if you see the pink (end of paper) markings, pause the report and change the paper.



If the paper runs out while printing, the DS200 will reprint the last 18 lines before the paper ran out on the new report. You will need to find the last entry on the old roll and use the timestamps to find the repeated entries on the new roll.

The DS200 generates the following report types:

Election Startup Reports

Poll Closing Report

Election Startup Reports

The DS200 prints the following reports when you are opening polls:

- ❖ **Ballot Status Accounting Report**
- ❖ **Zero Totals**

Ballot Status Accounting Report

The Ballot Status Accounting Report is a descriptive list of system settings that automatically generates when you turn on the scanner. The report includes a list of election configuration settings if the election definition is loaded when you turn on the scanner.

Sample Ballot Status Accounting Report

*** BALLOT STATUS ACCOUNTING REPORT ***

9:07 AM October 24, 2007

Unit S/N: 0107380021

ANY CITY

2006 GENERAL ANY STATE

1 POLL 1

Election Date: September 06, 2008

Poll Opened Date: November 12, 2007

Poll Opened Time: 3:48 PM

Poll Closed Date: November 12, 2007

Poll Closed Time: 3:49 PM

Public Count: 10

Poll Voting Report

Total Ballots: 10

Ballots for Code00001-01-010

Ballots for Code00002-01-011

Ballots for Code00003-01-012

Ballots for Code00004-01-010

Ballots for Code00005-01-011

Ballots for Code00006-01-012

Ballots for Code00007-01-010

Ballots for Code00008-01-011

Ballots for Code00009-01-012

Ballots for Code00010-01-010

Ballots for Code00011-01-011

*** END OF REPORT ***

Daily Ballot Status Accounting Report

The Daily Ballot Status Accounting report contains daily ballot counts across a multi-day voting period, for example, an Early Voting period. Poll workers can use the report to reconcile paper ballots at the polls on a daily basis. The following is an example of the Daily Ballot Status Accounting report.

```

*** BALLOT STYLE COUNTS ***
*** PER ELECTION DISTRICT ***
2:54 PM November 19, 2009
Unit Serial Number: 0107370076
1 POLL 1

ELECTION DISTRICT 1
Ballots for code 00001-01-01      2

ELECTION DISTRICT 2
Ballots for Code 00001-01-01      2

2:54 PM November 19, 2009
Unit Serial Number: 0107370076
1 POLL 1
Election Date: August 14, 2008
*** END OF REPORT ***

```

Follow the procedure below to produce the Ballot Status Accounting report while the polls are still opened:

1. Unlock the DS200 access door.
2. Press and hold down the **CLOSE POLLS** button, located above the power button

The close poll screen will appear.

3. Press **Admin** in the top right corner of the screen.



- The Voting Device Status Screen will appear. In this screen press **Exit**.



- This will make the Report Option button appear, Press **Report Options** to print the report or press **Go to Voting Mode** if you would like to continue voting.

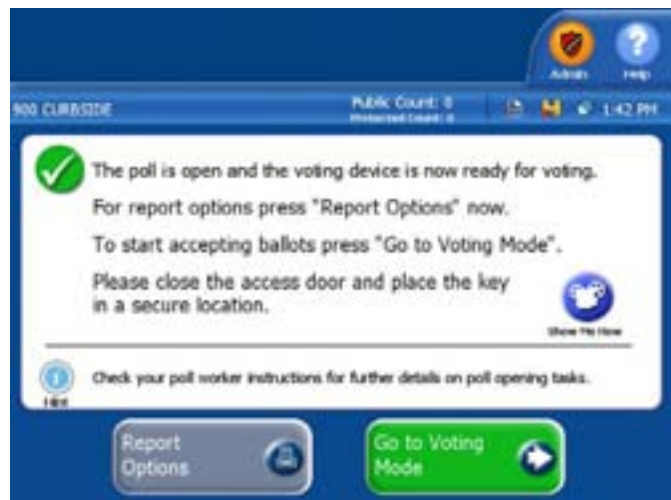

- Select the Ballot Status Accounting Report, then press Print Report to print a copy of the report.



Zero Totals

Use the zero report to ensure all of your contests have zero votes when the polls are initially opened.

Sample Zero Report

```

*** ZERO TOTALS REPORT ***
7:10 AM November 06, 2007
Unit Serial Number: 0107380003

  ANY COUNTY
  2006 GENERAL ANY STATE
  1 POLL 1
  Election Date: November 06, 2007
  Poll Opened Date: November 06, 2007
  Poll Opened Time: 7:10 AM
  Poll Closed Date: No
  Poll Closed Time: No
  Public Count: 0

  Poll Voting Report

  Total Ballots: 0

  GOVERNOR AND LT. GOVERNOR
  Number to Vote For      1

  REP WILLIAM SULLIVAN                0
  DEM STEPHEN MASSIMILIAN            0
  CON DOUGLAS STONE                   0
  LIB ANNE NEET                       0
  SWK FRANK L. MATTHEWS                0
  SLB ROBERT MARSH                     0
  LAB CHRISTOPHER R. RICHARDSON       0
  COM THOMAS REISS                    0
  COU WILLIAM MALICKI                 0
  FRE WILLIAM RHODES                  0
  Write-in                             0

  COMPTROLLER
  Number to Vote For      1

  REP MICHAEL SANTARCANGELO          0
  DEM CHERYL SIMON                   0
  CON PETER F. SAXTON                 0
  LIB FRANKLIN MARGO                  0
  SWK EUGENE RUFF                     0
  SLB ARTHUR SALAMACK                 0
  LAB THOMAS TURNER                   0
  COM KENNETH INTERLICHIO            0
  Write-in                             0

  WE, THE UNSERSINGED DO HEREBY CERTIFY
  THAT THE ABOVE RESULTS ARE A TRUE AND
  ACCURATE ACCOUNT OF ALL BALLOTS COUNTED
  AND THAT ALL COUNTERS WERE ZERO (0) WHEN
  THE POLLS OPENED AND THAT THE ELECTION WAS
  HELD IN ACCORDANCE WITH THE LAWS OF THE STATE.

  -----
  ELECTION JUDGE

  -----
  ELECTION JUDGE

  -----
  ELECTION JUDGE

  -----
  ELECTION JUDGE

  -----
  ELECTION JUDGE

  01 ANY COUNTY POLL
  UNITY Serial Number: 0101010111

  ***END OF REPORT***

```

The Ballot Status Accounting Report and Zero Report automatically print when polls open. To print the Event Log Report and Configuration Report, press **Report Options**.

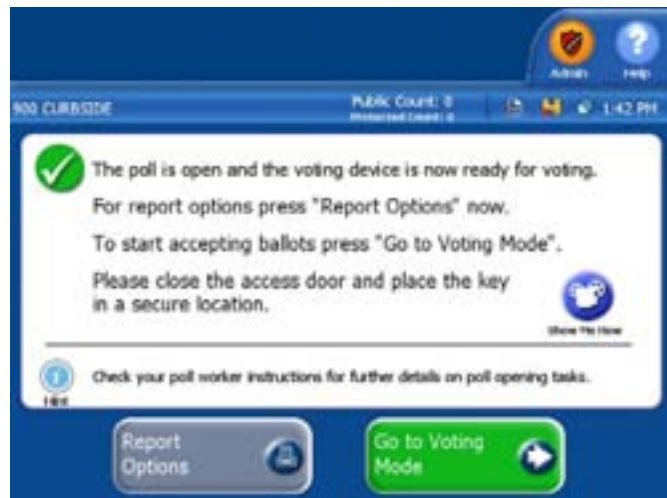

Once you press **Report Options**, select a report to print from the Reports screen.

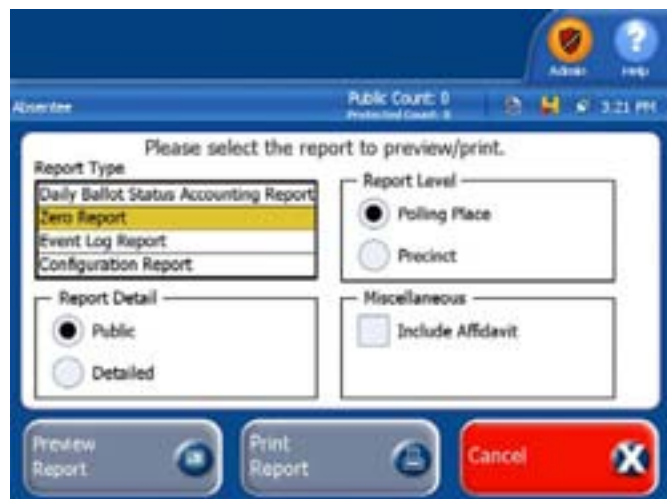

Event Log Report

The Event Log Report lists all of the scanner events that occur from the time you load your election definition USB flash drive into the scanner until you remove the flash drive after the election is complete.

Sample Event Log Report

```

*** EVENT LOG REPORT ***
9:34 AM January 18, 2011
Unit Serial Number: 0107370046

  TIME   DATE     MSG TYPE  MSG ID
MESSAGE TEXT
16:25:40 01/11/2011 P_LOG    1004139
Security Code Authenticated
16:25:43 01/11/2011 P_LOG    1004300
Attempting to Open Poll
16:31:28 01/11/2011 P_LOG    1004002
Election loaded
16:31:29 01/11/2011 P_LOG    6004022
Open process complete.
16:31:31 01/11/2011 P_LOG    6004121
Keys detected on poll media 0107370046
Audio state changed AUDIO_SESSION_IDLE
09:32:25 01/18/2011 P_LOG    1004143
Printing 1 copy of Configuration Report
09:32:30 01/18/2011 P_LOG    1004148
User canceled printing Configuration Report
09:32:31 01/18/2011 P_LOG    1004302
DS200/UVC not plugged in

0001 Poll 001
Unit Serial Number: 0107370046

*** END OF REPORT ***

```

Configuration Report

The Configuration Report lists information such as the storage memory availability, firmware information and basic scanner information such as the status of the touch screen and battery charge level.

Sample Configuration Report

```

*** CONFIGURATION REPORT ***
9:40 AM January 18, 2011
Unit Serial Number: 0107370046

VOTING DEVICE INFORMATION

HARDWARE CONFIGURATION
Current Time Date:
  9:40 AM January 18, 2011
Time Zone: America/Chicago
Diverter Status: Not Detected
Touch Screen: OK
Power Source: AC
Battery Charge: 100%
Modem Status: Not Detected
Universal Voting Console: Not Detected

STORAGE
Available System Log Storage: 22 MB
Available Ballot Storage: 1751 MB
Available Backup Storage: 0 MB

FIRMWARE
Paper Processing Engine: 2.4.0.0x
Hardware Abstraction Engine: 2.4.0.0x
Tabulation Engine: 2.4.0.0x
Scanning Engine: 2.4.0.0x
Presentation Engine: 2.4.0.0x
Scanner Firmware: 2.13.0.0a
Power Management Firmware: 1.2.2.0a
Operating System Version: 2.4.0.0x
Firmware Last Updated On:
  Unknown
Protected Count: 0

ELECTION QUALIFICATION INFORMATION
Election Name: TULSA
Election Date: 2010-12-31
Election Qualification Code: 05b1e725

ELECTION LOADED

ELECTION STATUS
Poll Opened Date: January 11, 2011
Poll Opened Time: 4:31 PM
Poll Closed Date: January 11, 2011
Poll Closed Time: 4:44 PM
Poll Status: Closed
Public Count: 1

ELECTION INFORMATION
Jurisdiction Name:
  TULSA
Election Description:
  TULSA
Election Date: December 31, 2010
Poll Place ID/Name:
  863/Poll 001
Election Type: GENERAL
Number of Precincts: 1

BALLOT INFORMATION
Ballots By: Style
Ballot Height: 17.0
Ballot Width: 8.5
Ballot Rows: 62
Ballot Columns: 24
Ballot Art Work: DSIM
Target Type: oval

ELECTION SETTINGS
Ability to Re-open: Yes
Number of Zero Tapes to Print: 1
Number of Result Tapes to Print: 1
Print Event Log on Close: No
Transmit Results on Close: No
Report Detail: Media
Report Level: Poll
Candidate Sort Order:
  Default Candidate Order
Single Over-Vote: No
Combine Over and Under Votes: No
Save Ballot Images: All

EXCEPTION BALLOT SETTINGS
Blank Ballots: Query
Over-voted Ballots: Query
Under-voted Ballots: Query
Marginal Marks: Reject
Cross-over Ballots: Query

DIVERTER SETTINGS
Diverter Installed: No
Identify Write-in Overvotes: No
Identify Blank Ballots: No
Identify Write-ins: No

*** END OF REPORT ***

```

Poll Closing Report

The DS200 prints the following report when you are closing the polls:

- ❖ Ballot Status Accounting Report
- ❖ Results Report

Results Report

The Results Report prints the results of your elections.

Sample Results Report

```

***VOTING RESULTS REPORT***
10 48 AM January 18, 2011
Unity Serial Number: 018738001

AnyCounty USA
AnyCounty USA
01 AnyCounty Poll
Election Date: July 04, 2011
Poll Opened Date: July 04, 2011
Poll Opened Time: 8:00 AM
Poll Closed Date: July 04, 2011
Poll Closed Time: 3:00 PM
Public Count: 11
↓
Poll Voting Report

Total Ballots: 11

FOR PRESIDENT
Number to Vote For          1
REP-ABRAHAM LINCOLN         3
DEM-ANDREW JACKSON          0
LIS-GEORGE WASHINGTON       8
Write-in                    0

FOR GOVERNOR
Number to Vote For          1
REP-ED MCMAHON              3
DEM-JOHNNY CARSON           7
LIS-MERV GRIFFIN            0
Write-in                    0

FOR COUNTY CLERK
Number to Vote For          1
REP-ELVIS PRESLEY           5
DEM-WLADISLAV VALENTINO LIBERACE 1
LIS-KAREN CARPENTER         4
Write-in                    0

QUESTION 1
FOR                          6
AGAINST                       4

WE, THE UNDERSIGNED, DO HEREBY CERTIFY
THAT THE ABOVE RESULTS ARE A TRUE AND
ACCURATE ACCOUNT OF ALL BALLOTS COUNTED
AND THAT ALL COUNTERS WERE ZERO(0) WHEN
THE POLLS OPENED AND THAT THE ELECTION WAS
HELD IN ACCORDANCE WITH THE LAWS OF THE
STATE

-----
Election Judge
-----
Election Judge
-----
Election Judge
-----
Election Judge
01 AnyCounty Poll
Unity Serial Number: 018738001
***END OF REPORT***

```

The Results Report automatically prints when polls close. To print the Event Log Report and Configuration Report, press **Report Options** in the Open Polls window.



Once you press **Report Options**, select a report to print from the Reports screen.

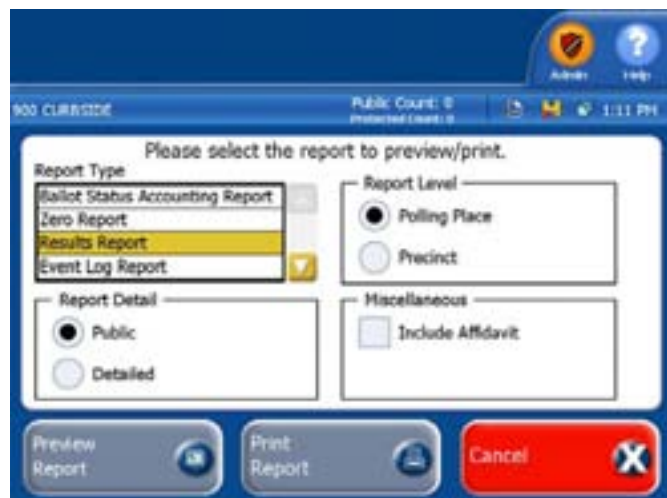

Chapter 8: Scanner Maintenance

Perform the following maintenance tasks to keep your DS200 scanner in proper working order:

- ❖ **Clean the Scanner**
- ❖ **Clean the Ballot Box**
- ❖ **Replace the Paper Roll**
- ❖ **Replace the Write-in Stamp**
- ❖ **Maintain the Scanner Battery**
- ❖ **Preventative Maintenance During High Volume Accuracy Testing**

Clean the Scanner

Clean your scanner before and after each election.

1. Turn off the scanner and unplug the power cord.



Electrical Shock Danger: Always unplug the AC power cord and turn the scanner off before you clean a DS200 scanner.

2. Clean the ballot entry and exit slots with a can of pressurized clean, dry air or inert gas, which is available for order from ES&S. Aim the air can's spray tube into the ballot entry slot and blow out all the debris. Clean the ballot exit slot in the same way. Repeat the entire procedure and inspect the entrance and exit slots with a flashlight.
3. Use pressurized air to remove dust and debris from around the menu display.
4. Use a soft, lint-free cloth and water, or isopropyl alcohol to wipe down the scanner. Dampen, do not soak, the cloth with the cleaning solution. Do not spray cleaning solution directly onto the scanner.
5. Clean the LCD display window with the damp cloth. Be careful not to scratch the display panel.
6. Use the cloth and cleaning solution to clean the scanner's outer case. Start at the top and work down to the base.
7. Clean the scanner's stainless steel base plate with the cleaning solution. Wipe all traces of the cleaning solution off the scanner after you finish cleaning.

8. Unlock the rear access door on the back cover of the DS200.



9. Once this door is unlocked and back cover of the DS200 is raised, the ballot transport mechanism can be opened.
10. Lift up the latches on the left and right side of the ballot transport.

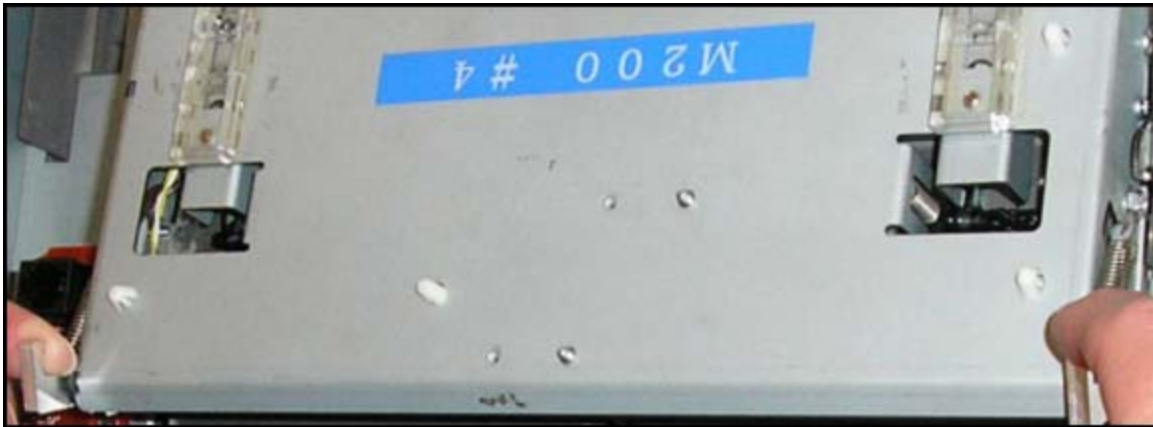

11. Lift up the top cover to access the ballot transport.

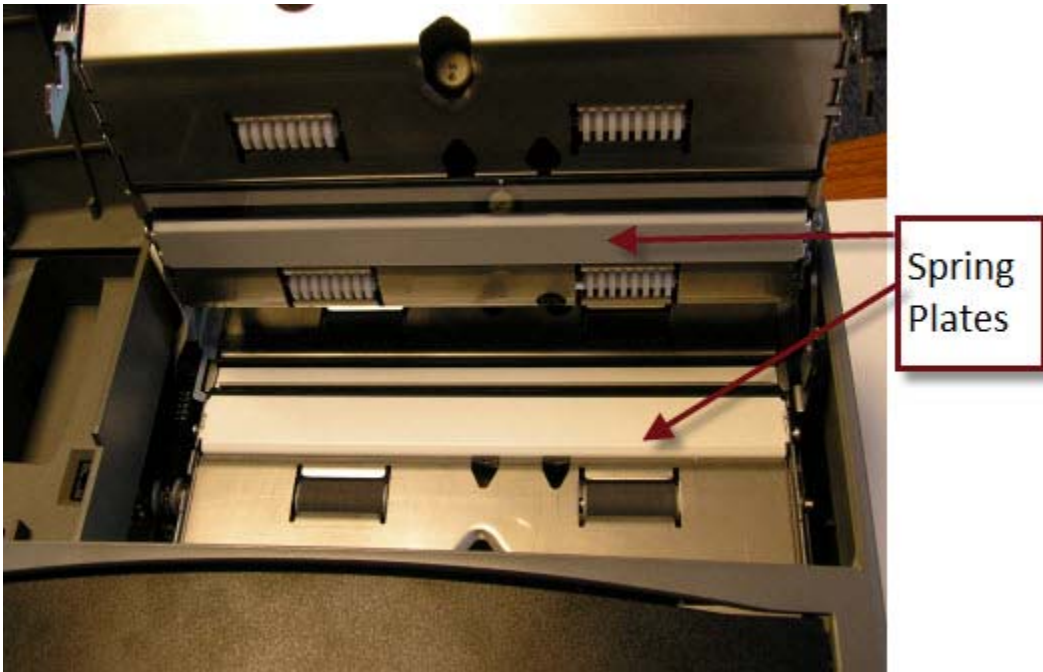

12. Use a lint-free cloth and isopropyl alcohol to clean the spring plates opposite the contact image sensors.
13. Clean the rubber rollers on the bottom surface of the ballot transport.

Clean the Ballot Box

Clean your DS200 ballot boxes either before or after each election. Use a mild solution with water and soap to clean the ballot boxes.

Clean the Plastic Ballot Box

1. Use a cloth dampened with cleaning solution to clear dust and debris from the ballot box.
2. Open the door to the ballot bin.
3. Wipe down the interior ballot divider with the cleaning cloth and the box cover. Remember to periodically rinse the cleaning cloth.
4. Remove the DS200 carrying case on top of the ballot bin to expose the emergency ballot bin.
5. Wipe down the interior emergency ballot bin with the cleaning cloth.

6. Place the DS200 carrying case on top of the ballot bin when you are finished cleaning the emergency ballot bin. Make sure the wheels from the carrying case fit into the holes in the emergency ballot storage bin.

Clean the Metal Ballot Box

1. Use a cloth dampened with cleaning solution to clear dust and debris from the ballot box.
2. Remove the divider from the lower ballot bin before you clean the bottom section of the ballot box. Clean inside of the bin first and then the outside. Wipe down the interior ballot divider and the box cover. Remember to periodically rinse the cleaning cloth.
3. Stand the ballot box upright to clean the recessed scanner housing.



Warning: Make sure the power cord and the diverter motor connector are not damaged or dirty.

4. Turn the mounting pedestal upside down and clean the inside of the box. Use a soft cleaning brush or feather duster to clear dust and debris. Use a brush to clean the diverter vane, diverter motor, and controller circuit board for the ballot diverter. Do not bend or damage any of the sensitive components contained in the diverter motor assembly.
5. Use a brush to clean the debris and dust from the ballot chute assembly. Do not use liquids to clean the inside of the scanner mounting pedestal. Re-assemble the unit after you finish cleaning.

Replace the Paper Roll

Check the DS200 printer and change the paper roll, if necessary, for Election Day



Note: A warning message may appear if the internal printer is out of paper.

1. If a security seal is placed on the access door, follow your jurisdictions guidelines for removing and recording security seals. Unlock the access door, located above the printer. This will provide access to the printer release lever.

2. Press the lever to unlock the printer door.
3. Open the printer door.

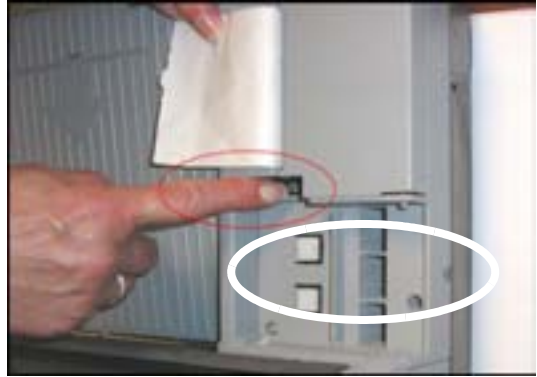

4. Remove the remaining old paper roll.
5. Drop the paper into the printer paper compartment.



Important: Make sure the glossy side of the thermal paper is facing the thermal printer.

6. Pull the end of the paper roll out toward the input tray of the DS200.
7. Close the printer door and press firmly on the door to make sure it locks into place.
8. Lock the access door above the printer. If a security seal was removed, follow your jurisdiction's guidelines for replacing security seals.



Important: If the printer door is not properly locked in position, the printer may not function.

Replace the Write-in Stamp

The DS200 is equipped with a stamp that marks ballots containing write-in votes. The stamp should be replaced prior to each election.

1. On the back of the DS200, locate the white knob.



2. Pull the knob to open the access door.



- 3.

4. Locate the stamp in the middle of the compartment.
5. Insert the stamp with the plastic portion of the stamp on top.



6. Ensure the access door is closed.



Maintain the Scanner Battery

The DS200 uses an 18.5 volt, 4300mAh lithium ion battery to power the scanner in case of an electrical power failure. A fully charged battery can power an “active” scanner for up to two hours and an “idle” scanner for up to three hours. The machine is “active” when counting ballots or printing reports. Estimated battery life is five years.

To check the charge for your backup battery, look at the light indicator on the back of your DS200 machine.

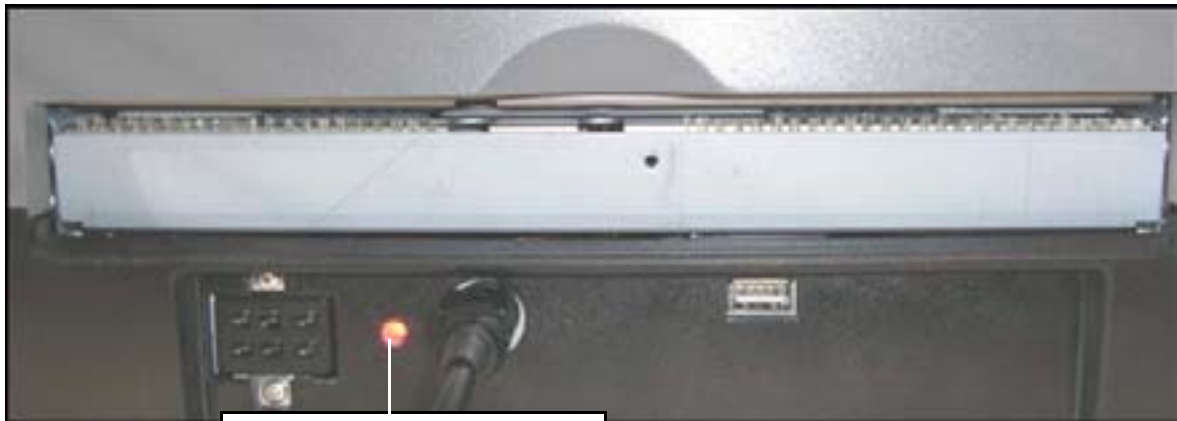

Battery Power Indicator

- ❖ If the light is flashing **green**, the battery is charged.
 - If the light is green and not flashing, the DS200 is plugged in and the battery is fully charged.
 - If the light is flashing at a slow rate, the DS200 is operating on battery power and the battery has 75 percent or more of its charge remaining.
 - If the light is flashing at a medium rate, the DS200 is operating on battery power and the battery has 50 percent of its charge remaining.
 - If the light is flashing at a fast rate, the DS200 is operating on battery power and the battery has 25 percent of its charge remaining.
- ❖ If the light is **amber**, the battery is charging. If the light is amber, allow the DS200 to charge until the light turns green. If the battery is not charged, it will take up to six hours to charge the battery.
 - If the light is flashing at a slow rate, the battery is 75 percent charged.
 - If the light is flashing at a medium rate, the battery is 50 percent charged.
 - If the light is flashing at a fast rate, the battery is 25 percent charged.
- ❖ If the light is **flashing red**, the battery is not taking a charge. This could be caused by:
 - A dead battery.

- A bad connection to the battery.
- No battery is in the DS200.



Note: If the DS200 has not operated on battery power and was stored with a full battery charge, the charge time required to fully recharge the battery will be minimal.

Battery Cautions



Electrical Shock Danger: Removing the battery from the scanner exposes it to risks that are not present under normal operating conditions.

Shorting the battery terminals together is especially hazardous even if the battery is “discharged” or “dead.” Shorting the terminals can create sparks, melt wires, and possibly start a fire. Use extreme caution when handling the backup battery.



Note: The DS200 battery may be recycled. Please dispose of the battery properly.

Charge the Battery

The amount of time required to charge a battery can be anywhere from five minutes to seven hours, depending on the battery’s current charge.



Reference: Refer to the [Charge the Battery](#) heading of [Chapter 4: Pre-Election Day Tasks](#) for more information about the battery power icons.

Preventative Maintenance During High Volume Accuracy Testing

During high volume or accuracy testing, you must perform preventative maintenance at a higher frequency due to the high amount of ballot processing. ES&S requires that preventative maintenance be performed prior to the start election test, and after every 2,000 processed ballots.

After the DS200 has completed each batch of ballots and printed the operations log, take the following steps in addition to the standard preventative maintenance routine.

1. Turn off the scanner and unplug the power cord.

2. Clean the ballot entry and exit slots with a can of pressurized clean, dry air or inert gas, which is available for order from ES&S. Aim the air can's spray tube into the ballot entry slot and blow out all the debris. Clean the ballot exit slot in the same way. Repeat the entire procedure and inspect the entrance and exit slots with a flashlight.
3. Use pressurized air to remove dust and debris from around the menu display.
4. Use a soft, lint-free cloth and water or a mild solution of water and soap to wipe down the scanner. Dampen, but do not soak the cloth with the cleaning solution. Do not spray cleaning solution directly onto the scanner.
5. Clean the LCD display window with the damp cloth. Be careful not to scratch the display panel.
6. Use the cloth and cleaning solution to clean the scanner's outer case. Start at the top and work down to the base.
7. Clean the scanner's stainless steel base plate with the cleaning solution. Wipe all traces of the cleaning solution off the scanner after you finish cleaning.
8. Unlock the rear access door on the back cover of the DS200.



Electrical Shock Danger: Always unplug the AC power cord and turn the scanner off before you clean a DS200 scanner.

9. Once this door is unlocked and back cover of the DS200 is raised, the ballot transport mechanism can be opened.
10. Lift up the latches on the left and right side of the ballot transport.
11. Lift up the top cover to access the ballot transport.
12. Use a lint-free cloth and isopropyl alcohol to clean the glass surface of the contact image sensors.
13. Clean the rubber rollers on the bottom surface of the ballot transport

Part 4: Appendix

Part 4 contains information about the following topics.

- ❖ [Chapter 9: DS200 Quick Start Guide](#)
- ❖ [Chapter 10: Troubleshooting](#)
- ❖ [Chapter 11: System Messages](#)

Chapter 9: DS200 Quick Start Guide

This chapter contains a brief overview for using the DS200, from attaching the DS200 to the ballot box to closing the election polls. The tasks described in this chapter will normally be used by poll workers on Election Day. The information in this chapter is explained in more detail in later chapters.

- ❖ If you are using the plastic ballot box, follow the instructions under the [Attach the DS200 to the Plastic Ballot Box](#) heading.
- ❖ If you are using the metal ballot box, follow the instructions under the [Attach the DS200 to a Metal Ballot Box](#) heading.

Attach the DS200 to the Plastic Ballot Box



If the plastic DS200 ballot box is not assembled, refer to the [Assemble the Plastic Ballot Box](#) section in [Chapter 4: Pre-Election Day Tasks](#) for ballot box assembly instructions.

The DS200 is typically operated on a secure ballot box.

1. Use the DS200 key to open the front of the DS200 carrying case.



2. Press up on the two tabs to unlock the DS200 carrying case.



3. Inspect the power cord for damage before you mount your scanner to the top of the ballot box.



Electrical Shock Danger: If the cord appears damaged, discard it and contact ES&S for a new cord.

4. Place the scanner about one-third of the way into the recessed area and slide it onto the mounting rails until it sits about four or five inches (0.1 meters) from the back of the recessed area.



Electrical Shock Danger: Only plug the DS200 scanner into a grounded, three-pronged electrical outlet. Plug only one scanner into each available outlet. ES&S does not recommend using an extension cord.

5. Plug the power cord into the power port on the back of the scanner and then plug the AC power cord from the external power supply into a 120-volt wall outlet. Arrange your voting equipment to make sure that no one trips on the cord or accidentally unplugs the scanner on Election Day.



Note: A “No Input Power Detected” message appears on the scanner’s display screen and a “Switched to Battery Power” message is added to the audit log if the scanner is not receiving power through the power cord. Check your connections and the wall outlet if this message appears on your scanner’s display screen. After the scanner has been re-connected through the power cord, a “Switched to AC Power” message is added to the audit log.

6. Slide the scanner against the back of the DS200 carrying case. The scanner will press against the two protective foam inserts.



7. Raise the hinged access door on the DS200 carrying case and lock the hinged door into place to secure the scanner in the carrying case.



Test the door to make sure the lock properly engages. If the door cannot be locked, the DS200 may not be pushed completely up against the back of the DS200 carrying case.

Fully Assembled Ballot Box



Attach the DS200 to a Metal Ballot Box

The DS200 can operate on a secure metal ballot box. The metal ballot box does not require assembly.

1. Before you mount your scanner to the top of a ballot box, inspect the power cord for damage.



Electrical Shock Danger: If the cord appears damaged, discard it and contact ES&S for a new cord.

2. Insert the DS200 power cord from the external power supply through the opening on the outer left side of the ballot box.
3. Make sure the hinged plate covering the ballot slot is in the open or upright position.
4. Thread the cord through the outside opening on the back of the box until the cord appears on the inside of the opening at the top recessed area.
5. Place the scanner about one-third of the way into the recessed area and slide it onto the mounting rails until it sits about four or five inches from the back of the recessed area.



6. Plug the power cord into the power port on the back of the scanner.

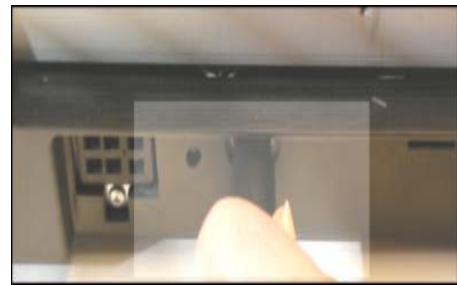

7. Slide the scanner against the back of the ballot box. Make sure the diverter connector at the back of the scanner locks into the slot on the ballot box.
8. Plug the AC power cord from the external power supply into a 120-volt wall outlet.



Electrical Shock Danger: Only plug the DS200 scanner into a grounded, three-pronged electrical outlet. Plug only one scanner into each available outlet. ES&S does not recommend using an extension cord.

9. Raise the hinged access door on the front of the ballot box and lock the hinged door into place. This helps secure the DS200 in place. Test the door to make sure the lock properly engages. If you cannot lock the door, the DS200 may not be pushed completely up against the back wall of the ballot box.

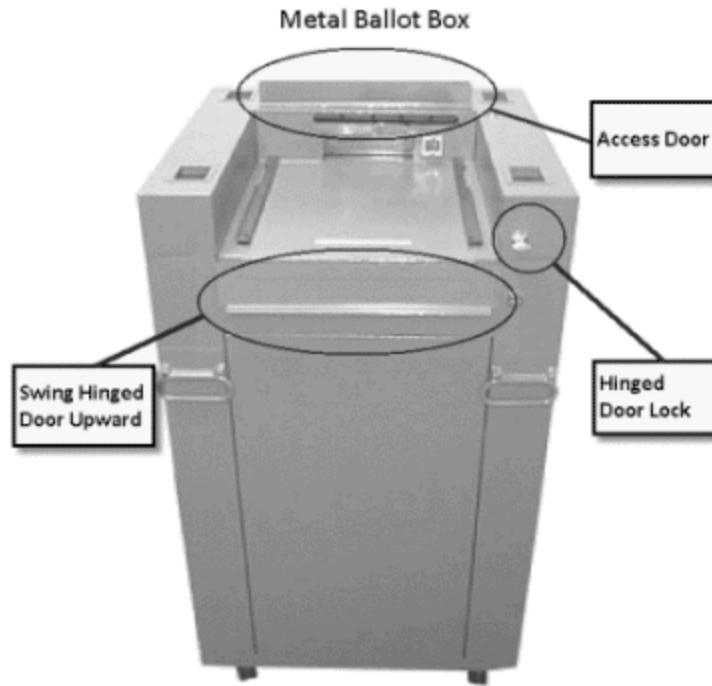

Seals and Locks

DS200 Seals and Locks

1. Insert the USB flash drive containing the election definition.
2. Secure the USB flash drive with a seal.
3. Close and lock the front access door. Assure that the front access door is locked and place a tamper evident seal as shown.
4. Insert the USB Backup Memory Device in the rear compartment. If your election rules require the use of a backup memory device, you should secure the USB Backup with a seal.
5. Close and lock the rear access door. Assure that the rear access door is locked and place a tamper evident seal as shown..
6. Close the display and lock. A tamper evident seal may be placed vertically from the lock to the display as shown.



DS200 Carrying Case and Ballot Bin Security Seals

The DS200 carrying case and ballot bin has nine possible locations for wire-type seals.

A. To secure the carrying case to the bin, engage the locks on the sides of the bin between the handles, then place one seal on each side of the bin between the handles (two seals).

B. To secure the ballot bin, assure that both doors are locked and place one seal on each door (two seals).

C. To secure the carrying case lid, secure both lid latches and lock the lid using the lock between the two latches. Place at least one seal on the lid latch. There are two locations for seals on each latch. Only one seal should be necessary to secure the lid.

D. To secure the DS200 inside the carrying case, lock the front door and place a seal through the lock bracket.

E. Further polling site security may be attained by using the integrated anchor point on the DS200 Ballot Bin.



Note: ES&S does not recommend any specific lock for this application due to the unknown anchor points at your polling sites. Check with your local hardware, sporting goods or computer supply store for options.

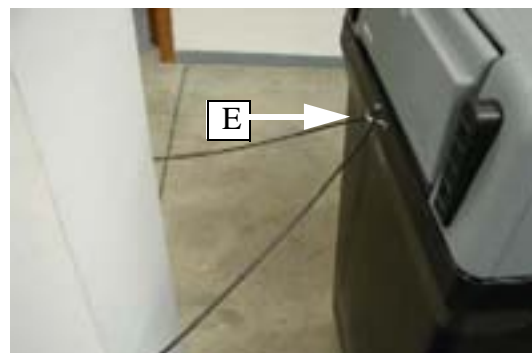
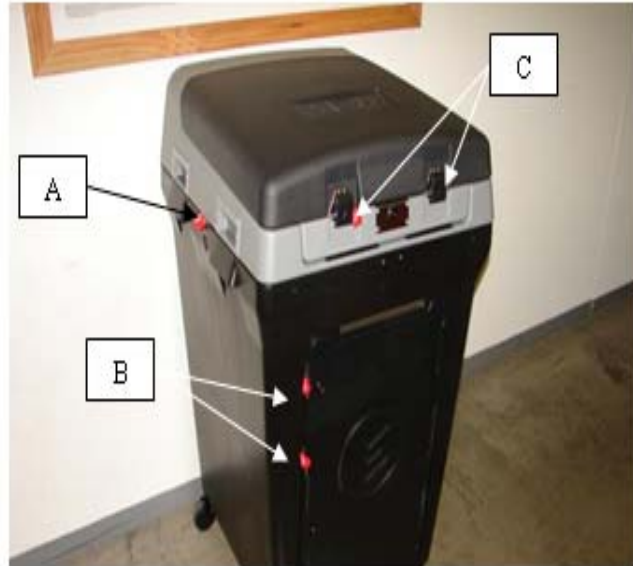

Steel Ballot Box

The steel ballot box has six possible locations for seals.

A. Slide the tabulator onto the ballot box rails and secure. A tamper evident seal can also be added for additional security.

B. Access to the emergency ballot bin is limited by this lock. A tamper evident seal can also be added for additional security.

C. When the scanner is in operation the ballot flap must be in the up position. During storage, transportation or periods of higher security, the ballot flap should be in the closed position and locked, using the lock next to the ballot flap.

D. Access scanned ballots through doors located on each side of the ballot box. These doors should be locked, and a tamper evident seal can also be added for additional security.

E. Additional security can be implemented by adding a seal on the bottom of the ballot box door.

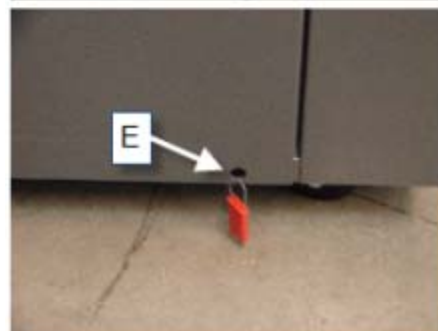
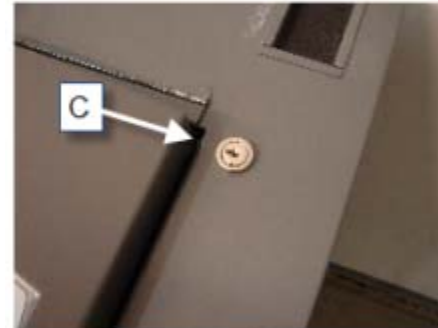

Open the Polls

After you have inserted the USB Backup Memory Device (if one is required), configured, tested and loaded the election definition. Use the following instructions to prepare the scanners for voting.



Important: Make sure the DS200 is plugged into an AC power source before you turn on the scanner.

1. Unlock the front of the DS200 machine



2. Flip up the LCD screen on the DS200

The DS200 unit automatically powers up when you raise the LCD screen and prints the Configuration Report.



3. If your DS200 does not power up, unlock the access door covering the power button.

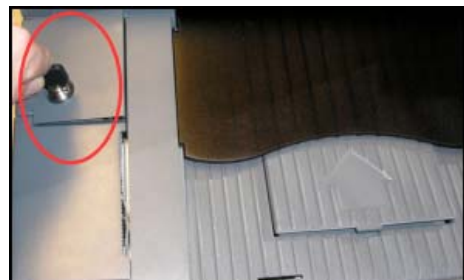

4. Press the bottom button to turn on the DS200.



Note: If you get the Enter Qualification Code screen you will need to contact your Election Headquarters for the proper procedures. See [Load the Election Definition](#) in [Chapter 4: Pre-Election Day Tasks](#) to load the Qualification media.

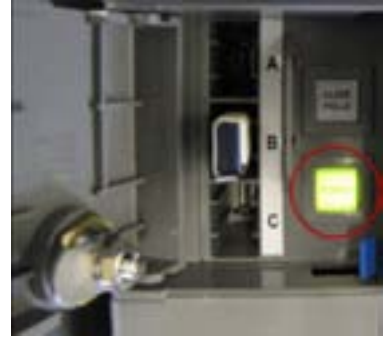

5. If the Election USB media has not been installed, insert the Election media from the current election to prepare the DS200 for the current election. If the Election USB media has already been loaded, go to [Step 7](#).

6. Enter your Election Code and press **Accept**, the system will validate the USB flash drive.



After the code is accepted, the system initializes and generates the following message if an election definition is found.



If an election definition is not found, the system displays the following message.



7. Press **Open Poll**. The DS200 prints the Ballot Status Accounting Report and the Zero Report.

In addition to printing the report, the system performs an internal self-test.

- The results of the internal self-test will appear on the screen.
 - If the DS200 fails any of its self-tests, the system automatically shuts down.
8. Close and lock the access door covering the power button.

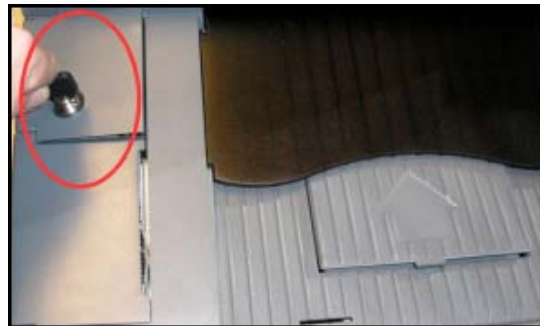

Once the report finishes printing the startup reports, the following screen appears.

9. Press **Go To Voting Mode**.

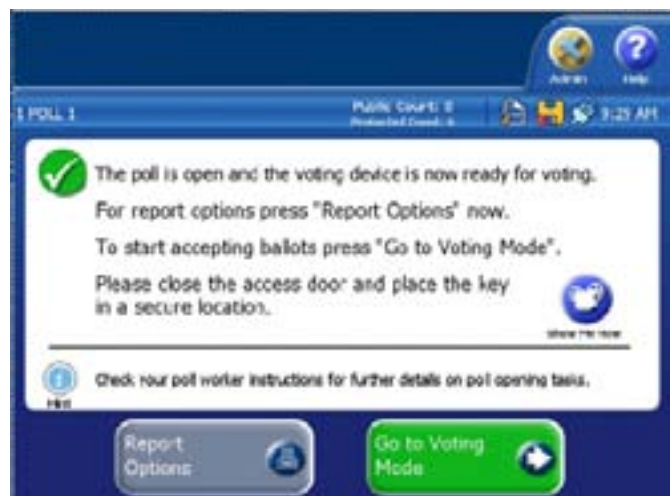

The DS200 is ready to receive Election Day ballots.



Close the Polls

1. Unlock the access door, located above the printer.
2. Press the **Close Polls** button, which is located above the power button. The following screen appears.

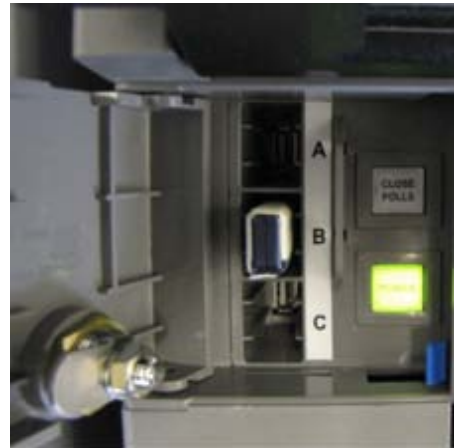

3. Press **Close Poll** to continue closing or press **Don't Close - Keep Voting** to cancel closing the polls.



Once you press the **Close Polls** button, the DS200 will automatically print a Ballot Status Accounting Report and a Results Report.



The number selected in the **Result Report Quantity** box in the DS200 Settings in ElectionWare will be the number of results reports printed. If you selected zero, The DS200 will not print a results report.



Refer to the *ElectionWare System Operations Procedures* manual for more information about setting DS200 options.

When all reports have printed, the following screen appears.

4. Press **Finished - Turn Off** the scanner will turn off automatically.



Once the Power button light is off, the USB flash drive can now be removed from the DS200.



Warning: Do not attempt to remove the USB flash drive before the Power button light is off, otherwise you may damage the flash drive.

5. Follow your jurisdiction guidelines for handling the USB flash drive and the printed reports.

Chapter 10: Troubleshooting

This chapter provides instructions for the steps to take for some common issues that may occur with the DS200. Take these steps before you call for Technical Service.

Emergency Ballot Storage Bin

If the DS200 fails during an election, use the following procedure to store ballots in the emergency bin until you can repair or replace the scanner.

- ❖ **Metal Ballot Box** - Make sure the top hinged panel is in the raised and locked position. Unlock the door to the emergency ballot storage bin and rotate the inside cover on the lower hinged panel to gain access to the storage bin slot. Swing the panel back up and lock in place.



- ❖ **Plastic Ballot Box** - Unlock the door to the emergency ballot bin on the front of the ballot bin. Swing open the door to access the ballots. Lower the



Voters may now insert ballots into the newly exposed slot for emergency storage. Store uncounted ballots in the emergency ballot storage bin until you can repair or replace the scanner.

Recovering or Replacing the DS200

Follow the steps below if one of your scanners fails and must be replaced:

1. Turn the malfunctioning scanner off by holding down the power button for about 30 seconds. Once the scanner powers down remove the election definition USB flash drive from the slot.



Note: Do not remove back up USB flash drive.

2. Verify that the election administrators have used Qualification media from the current election to clear and prepare the replacement DS200.
3. Insert the USB flash drive into the replacement scanner, and turn the power on. The replacement DS200 validates the USB flash drive's poll place media. If the revalidation fails, you will receive a message that the validation has failed.
4. If the replacement was properly validated then enter your Election Code. Once the DS200 accepts the code it writes the encrypted data to the root of the USB flash drive.
5. A Configuration Report will print after the security code is successfully entered.



Note: A backup USB flash drive will have to be in the replacement machine when they run the EQC process, before sending out to the polling location. The header file that is written to the backup USB flash drive during the EQC is signed with the machine's private key.



Note: You may not have to re-enter the Election Security Code if this screen was setup to be bypassed.

6. After entering the election security code (if required) the Polls Close screen appears.

7. Press **Report Options** if you desire to print a zero report or any other report. When you are ready press **Don't Close Keep Voting**.
8. The replacement unit is now ready to continue voting.



Reference: For more information about resuming scanner operations, see the [Reopen the Polls Without Clearing Vote Totals](#) section in [Chapter 5: Election Day Tasks](#).

Alternative Scenario: The replacement DS200 fails

If the replacement DS200 fails, follow steps 1-3 from above. The replacement DS200 will then validate that the ballot and results data originated from either the original DS200 or the first replacement DS200 and has not been altered. Once the DS200 has validated the data, it will display the Security Code entry screen and you can then enter your Election Security Code to complete the setup process.

Calibrate the Touch Screen

If the DS200 screen does not respond to touch, or if a screen other than the one you selected appears, the screen may need calibration. Take the following steps to calibrate the screen:

1. If your DS200 scanner is turned on, remove all USB media devices from the DS200, including the backup USB device.

2. Unlock the access door to the DS200.

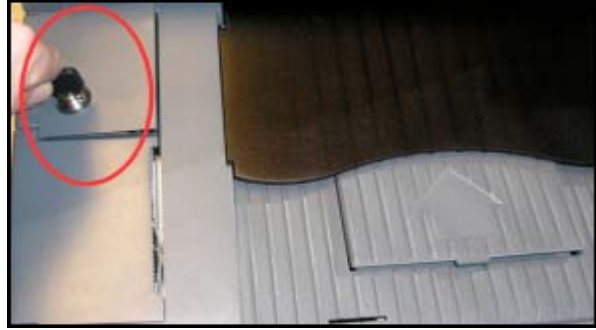

3. Press the top CLOSE POLLS button to access the calibration. turn on the DS200.
4. The following screen will appear. Press the circle in the upper-left corner of the screen. The following screen will appear.

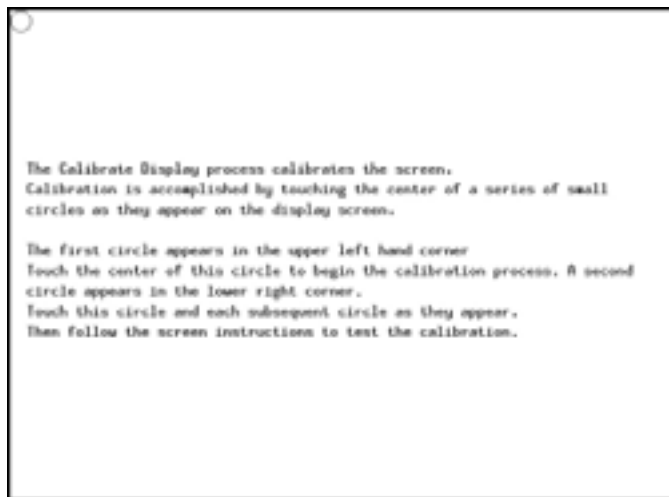

5. Press the circle in the lower-right corner of the screen. The following window will appear.

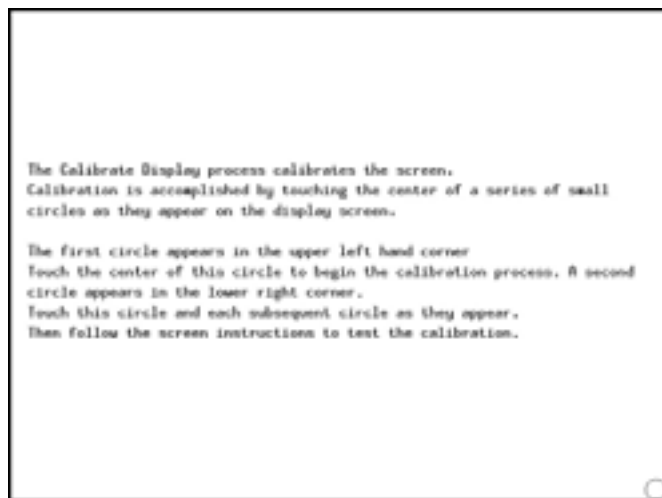

6. Press **Save & Exit** to save your changes. Press **Recalibrate** to recalibrate the scanner.



Note: If you do not press either button within 30 seconds, the window that appeared in Step 3 will appear and you will have to repeat steps 9 through 12.

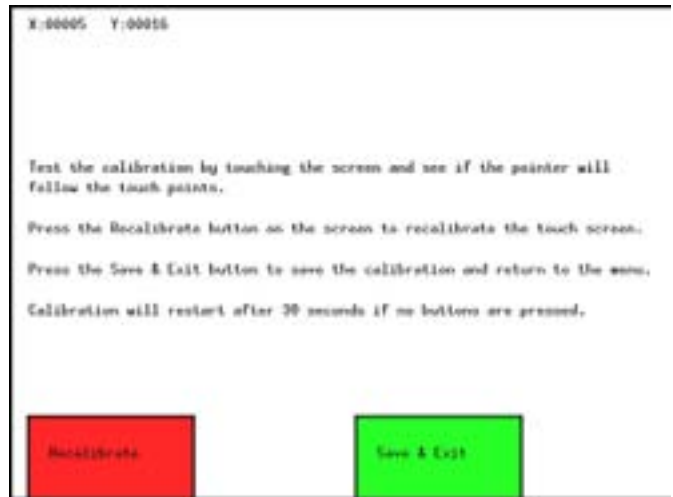

The DS200 logo appears on the screen when the DS200 is powering up.

7. When the Open Polls or Closed Polls screen appears, press the **Admin** button in the upper-right corner.



8. The Enter Election Code screen appears, asking for a code. Enter your security code and press **Accept**.



The Administration menu will appear.

9. From the Administration menu, press **System Settings**. The System Settings window will appear.



10. Press **Calibrate Touch Screen**.
The Calibrate Touch Screen will appear, then press **Continue**.



11. The following screen will appear. Press the circle in the upper-left corner of the screen. The following screen will appear.

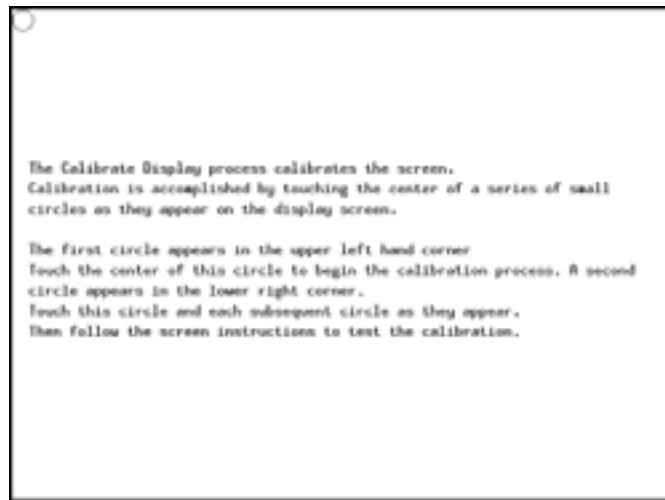

12. Press the circle in the lower-right corner of the screen. The following window will appear.

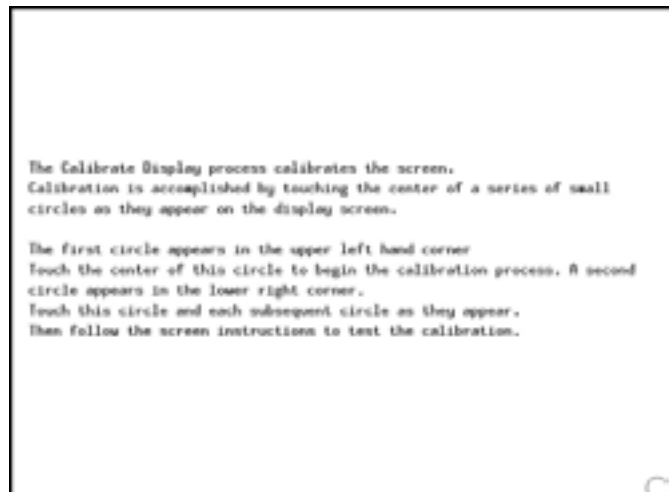

13. Press **Save & Exit** to save your changes. Press **Recalibrate** to recalibrate the scanner.



Note: If you do not press either button within 30 seconds, the window that appeared in Step 3 will appear and you will have to repeat steps 9 through 12.

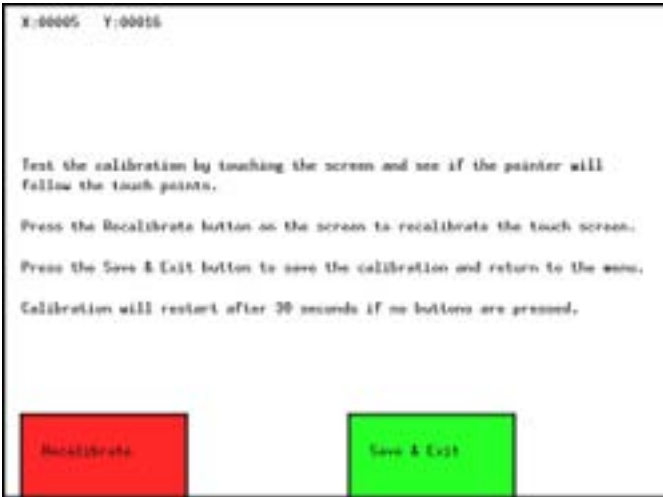

Chapter 11: System Messages

This chapter lists all system messages. In addition to the message itself, the scanner beeps to provide an audible cue that a message requires attention from a poll worker.



If you find your message in this chapter and still require assistance, contact your election administrator to schedule technical service or a back-up machine. Election administrators may contact ES&S at 877-377-8683.

System Error Recovery

If you encounter the “System Error” message, use the following process to continue counting ballots.

1. Open the access door on the front of the tabulator.
2. Hold down the power button for about four seconds to turn off the tabulator.
3. Remove the USB flash drive.
4. Make a duplicate copy of the USB flash.
5. Send the duplicate flash drive with the DS200 to ES&S for testing.
6. Replace the DS200 with the back-up DS200 tabulator assigned to your polling place.
7. Insert the original USB flash drive with the election definition
8. Press the power button to turn on the DS200.
9. Continue counting ballots.

Verification Messages

The following verification messages are self-explanatory, descriptive messages that the DS200 prints on the tape in response to a specific action. Verification messages do not require action from a poll worker.

- ❖ Counters Cleared
- ❖ Current Unit
- ❖ Diagnostic Check Completed
- ❖ Election Definition Loaded
- ❖ Election Definition Unloaded
- ❖ Entered Ballot Test Mode

- ❖ Exited Ballot Test Mode
- ❖ First Ballot Processed
- ❖ No Election Card
- ❖ Opening Polls
- ❖ Polls Closed
- ❖ Polls Opened
- ❖ Power On
- ❖ Real Time Clock Set
- ❖ Report Cancelled
- ❖ Switched to AC Power
- ❖ Switched to Battery Power
- ❖ Total Ballots Accepted
- ❖ Voting Enabled

Numeric Messages

System Messages

Error	Cause	Solution
1003001 – Unable to parse data file {1} : {0}	An error has occurred while starting the DS200.	Contact ES&S technical support.
1003002 – Unable to open data file {1} : {0}	An error has occurred while starting the DS200.	Contact ES&S technical support.
1003003 – Unable to close data file {1} : {0}	An error has occurred while starting the DS200.	Contact ES&S technical support.
1003004 – Internal system error parsing {1}, {2} factory not initialized	An error has occurred while starting the DS200.	Contact ES&S technical support.
1003005 – Data parsing error: {0} in {1} on < {2}>	An error has occurred while starting the DS200.	Contact ES&S technical support.
1003006 – Data parsing error: {0} in {1} on < {2}> for attribute {3}	An error has occurred while starting the DS200.	Contact ES&S technical support.

System Messages

Error	Cause	Solution
1003007 – Empty data file: {1}	An error has occurred while starting the DS200.	Contact ES&S technical support.
1003008 – Internal system error parsing class {1} does not implement {2}	An error has occurred while starting the DS200.	Contact ES&S technical support.
1003009 – Unable to open cursor image file for sip and puff device: {1}	An error has occurred while starting the DS200.	Contact ES&S technical support.
1003010 – Unexpected response from business: {1} for command {2}	An error has occurred while starting the DS200.	Contact ES&S technical support.
1003011 – Unable to get response from business for command {1}	An error has occurred while starting the DS200.	Contact ES&S technical support.
1003012 – Unknown response from business : {1} for command {2}	An error has occurred while starting the DS200.	Contact ES&S technical support.
1003013 – Invalid response from business: {1} for command {2}	An error has occurred while starting the DS200.	Contact ES&S technical support.
1003014 – Unable to communicate with business layer:{0}	An error has occurred while starting the DS200.	Contact ES&S technical support.
1003015 – Internal system error communicating to business: {0}	An error has occurred while starting the DS200.	Contact ES&S technical support.
1003016 – Unable to initialize printer: {0}	The DS200 cannot connect to the printer.	Contact ES&S technical support.
1003017 – Zoom data read failed: {0}	The DS200 cannot read Zoom data.	Contact ES&S technical support.
1003018 – Zoom requested for invalid contest id: {0}	Zoom data is being requested for an invalid contest id.	Contact ES&S technical support.
1003019 – Invalid contest type for zoom contest {1};{0}	There is an invalid contest type for zoom contest.	Contact ES&S technical support.
1003020 – Summary zoom requested for invalid contest id: {1}	Summary Zoom data is being requested for an invalid contest id.	Contact ES&S technical support.

System Messages

Error	Cause	Solution
1003021 – Audio file missing: {1}	An audio file is missing.	Contact ES&S technical support.
1003022 – Error playing audio file {1}:{0}	There is an audio file error.	Contact ES&S technical support.
1003023 – Not a plain Ogg/Vorbis - file. Unable to play: {1}	There is an audio file error.	Contact ES&S technical support.
1003024 – Unable to load image file {1}:{0}	The DS200 cannot load an image file during the open polls process.	Contact ES&S technical support.
1003025 – Invalid contest type for context {1}: {0}	A contest error has occurred during the open polls process	Contact ES&S for technical support.
1003026– Unable to create Zoom on Demand summary page for context {1}: {0}	The DS200 cannot create the Zoom on Demand summary page.	Contact ES&S for technical support.
1003027 – Unable to create Large Font Ballot summary page for contest {1} : {0}.	The DS200 cannot create the large font ballot summary page.	Contact ES&S for technical support.
1003028 – Invalid audio flag from business: {1}	The audio flag setting is invalid.	Contact ES&S for technical support.
1003029 – Unable to read report file: {0}	A printing error has occurred.	Contact ES&S for technical support.
1003030 – Invalid ESS Memory Device type: {1}	The memory device type is invalid.	Contact ES&S for technical support.
1003031 – Election ID mismatch	The election ID is mismatched.	Contact ES&S for technical support.
1003032 – Poll Place ID mismatch	The Poll Place ID is mismatched.	Contact ES&S for technical support.
1003033 – ESS Memory Device does not contain result data. You must use an ESS Memory Device that contains results to print the results report.	The USB flash drive does no contain election results data.	Replace the USB flash drive with a flash drive that contains the results data. Contact ES&S for technical support.

System Messages

Error	Cause	Solution
1003034 – ESS Memory Device contains results.	The USB flash drive contains election results data.	Contact ES&S for technical support.
1003035 – Maximum Security Code retry limit reached: {1}	The maximum number of unsuccessful security code entry attempts (3) has been reached. The scanner will shut down.	Contact your election official.
1003036 – Unable to open report file {1} : {0}	The DS200 is unable to open a report file.	Contact your election official.
1003037 – This is a Recovered ESS Memory Device. You must use an Election ESS Memory Device to load an election.	The DS200 is unable to open a report file.	Contact your election official.
1003038 – This ESS Memory Device was used to open the election on another terminal. You cannot collect Logic and Accuracy results with this ESS Memory Device.	The USB flash drive you are attempting to use has already been used to open an election a different DS200.	Contact your election official.
1003039 – ESS Memory Device contains election results for this terminal.	The USB flash drive contains election results for the terminal.	Contact ES&S for technical support.
1003040 – ESS Memory Device does not contain any Logic and Accuracy results to clear.	The USB flash drive does not contain any results.	Contact ES&S for technical support.
1003041 – A critical process error occurred in {1} process. The terminal will shutdown in sixty seconds.	An unspecified process error has occurred.	Contact ES&S for technical support.
1003042 – Printer Error: {1}	An unspecified printer error has occurred.	Contact ES&S for technical support.
1003043 – Unable to read firmware version number {1}: {0}	The scanner is unable to read the firmware version.	Contact ES&S for technical support.
1003044 – Unable to create report file {1} : {0}	The scanner is unable to generate a report.	Contact ES&S for technical support

System Messages

Error	Cause	Solution
1003045 – Event log file mismatch. This unit cannot be used for voting until the error has been corrected.	There is an event file log mismatch.	Contact ES&S for technical support
1003046 – Event log storage full. This unit cannot be used for voting until the error has been corrected.	The event log storage is full.	Contact ES&S for technical support.
1003047 – Missing Election Definition Information {2} in {1}	Election definition information is missing.	Contact ES&S for technical support.
1003048 – Unable to initiate firmware upload.	The DS200 cannot initiate the firmware upload.	Contact ES&S for technical support.
1003049 – Unable to start firmware upload. Battery too low to start the process.	The DS200 battery level is too low to start the firmware upload process.	Charge the battery and resume the firmware upload process upon completion. Contact ES&S for additional technical support.
1003050 – Unexpected response from paper processor: {1} for command {2}	An error has occurred while starting the DS200.	Contact ES&S for technical support.
1003051 – Unable to get response from paper processor for command {1}	An error has occurred while starting the DS200.	Contact ES&S for technical support.
1003052 – Unknown response from paper processor: {1} for command {2}	An error has occurred while starting the DS200.	Contact ES&S for technical support.
1003053 – Invalid response from paper processor: {1} for command {2}	An error has occurred while starting the DS200.	Contact ES&S for technical support.
1003054 – Unable to communicate with paper processor : {0}	An error has occurred while starting the DS200.	Contact ES&S for technical support.
1003055 – Data parsing error: {0} in {1} on <{2}>	An error has occurred while starting the DS200.	Contact ES&S technical support.
1003056 – Unable to retrieve version information from: {0}	The scanner encountered a problem while starting.	Contact ES&S for technical support.

System Messages

Error	Cause	Solution
1003057 – Failed Touchscreen Calibration	The scanner failed to process the touchscreen calibration.	Recalibrate the scanner. If this fails, contact ES&S for technical support.
1003058 – Internal system error parsing time value {1} :{0}	An error has occurred while starting the DS200.	Recalibrate the scanner. If this fails, contact ES&S for technical support.
1003059 – Event log failed	An error has occurred while starting the DS200.	Contact ES&S for technical support.
1003060 – Missing Ballot format information {2} in {1}	An error has occurred while starting the DS200.	Contact ES&S for technical support.
1003061 – Ballot found in scanner during startup is ejected	The scanner detected a ballot in the feed path during startup.	No action is needed.
1003062 – Ballot found in scanner during startup but could not be removed	The scanner detected a ballot in the feed path during startup.	Remove the ballot from the feed path
1004001 – Election preloaded : {0}	The election is preloaded onto the scanner.	No action is needed.
1004002 – Election Loaded	The election was successfully loaded onto the scanner.	No action is needed.
1004003 – Poll Opened	The poll(s) on the scanner are opened and ready to receive votes.	No action is needed.
1004004 – Zero Tape printed	The zero tape has printed.	No action is needed.
1004005 – Results collected	The results have been collected from the scanner.	No action is needed.
1004005 – Results collected	The results have been collected from the scanner.	No action is needed.

System Messages

Error	Cause	Solution
1004006 – Results recollected	The results have been recollected from the scanner during the reopen polls process.	No action is needed.
1004007 – Results printed	The results have printed.	No action is needed.
1004008 – Results Cleared	The results have been cleared from the scanner during the reopen polls process.	No action is needed.
1004009 – Election definition cleared	The election definition has been cleared from the scanner.	No action is needed.
1004010 – System Time Changed :{0}	The date and time on the scanner has changed.	No action is needed.
1004011 – Audio state changed :{0}	The audio state on the scanner has changed.	No action is needed.
1004012 – ESS Memory Device results cleared	The results on the USB memory stick have been cleared.	No action is needed.
1004013 – Poll Closed	The scanner successfully closed the poll.	No action is needed.
1004014 – Poll close time changed : {0}	The scanner closed poll time has changed.	No action is needed.
1004015 – Polls close time extended : {0}	The scanner closed polls time has been extended.	No action is needed.
1004016 – Shutdown initiated	The scanner is shutting down.	No action is needed.
1004017 – Voting session started	The voting session has started.	No action is needed.
1004018 – Selected ballot test canceled	The ballot test has been canceled.	No action is needed.
1004019 – Ballot activated	The ballot has been activated.	No action is needed.

System Messages

Error	Cause	Solution
1004020 – Party selection : {0}	Identifies party selection.	No action is needed.
1004021 – Party selection confirmed	Confirms party selection.	No action is needed.
1004022 – Voting session complete	The scanner has successfully scanned the ballot.	No action is needed.
1004023 – Entering poll worker mode	The poll worker mode is being entered.	No action is needed.
1004024 – No user activity	There is no user activity.	No action is needed.
1004025 – ***UNDER VOTE WARNING***	Undervotes are present.	No action is needed.
1004026 – Entering status screen	Entering information on status screen.	No action is needed.
1004027 – Voting session canceled. Session ID : {0} and Log ID : {1}	The voting session is canceled.	No action is needed.
1004028 – Ballot preparation canceled	Ballot preparation is canceled.	No action is needed.
1004029 – Candidate:	Identifies candidate.	No action is needed.
1004030 – Writein:	Identifies write-in.	No action is needed.
1004031 – Contest:	Identifies contest.	No action is needed.
1004032 – Ballot Summary	Identifies contest.	No action is needed.
1004033 – Choice:	Identifies choice.	No action is needed.
1004034 – Referendum:	Identifies referendum.	No action is needed.
1004035 – No selection(s) made	Identifies that no selection has been made.	Make the selection.
1004036 – Not all selections made	Notification that not all selections have been made.	Verify all selections have been made.
1004040 – ESS Memory Device restore completed	The restoration of the USB flash media is complete.	No further action is needed.

System Messages

Error	Cause	Solution
1004041 – Initializing Printer...	The printer is initializing.	No further action is needed.
1004042 – Ballot activated past poll close time	The ballot is activated past the poll close time.	No further action is needed.
1004043 – Closing polls early	The polls are closing early.	No further action is needed.
1004044 – Clear ESS Memory Device override	The clear for the USB memory device is being overridden.	No further action is needed.
1004045 – Override extend polls	You are attempting to override extend polls.	No further action is needed.
1004046 – Override recollect results	You are attempting to override recollect results.	No further action is needed.
1004047 – Override clearing with recovered ESS Memory Device	You are attempting to override clearing with a recovered USB memory device.	No further action is needed.
1004048 – Override clearing logic and accuracy results	You are attempting to override clearing logic and accuracy results.	No further action is needed.
1004049 – Override terminal not opened with current ESS Memory Device	You are attempting to override a DS200 that was not opened with a current USB memory device	No further action is needed.
1004050 – Override for changing poll close time	You are attempting an override in order to change the poll close time.	No further action is needed.
1004051 – Override for close pole early	You are attempting an override in order to close the poll early.	No further action is needed.
1004052 – Override for zero tape override	You are attempting an override.	No further action is needed.

System Messages

Error	Cause	Solution
1004053 – Initiated Touchscreen Calibration	The touchscreen calibration function has been initiated.	No action is needed.
1004054 – Completed Touchscreen Calibration Successfully	The scanner's touchscreen has been successfully calibrated.	No action is needed.
1004055 – Firmware update initiated	The firmware update process is being initiated.	No action is needed.
1004056 – Entering voting mode	The scanner has entered voting mode.	No action is needed.
1004057 – Printer error	A printing error has occurred.	Open the printer and check for a paper jam or check to see if the printer needs paper.
1004059 – Access attempt: {1}	You are attempting to access the DS200.	No action is needed.
1004065 – Ballot stored	The ballot has been stored.	No action is needed.
1004066 – Ballot preview started	The ballot preview process has been started.	No action is needed.
1004067 – Ballot preview finished	The ballot preview process has finished.	No action is needed.
1004068 – Selected ballot test started	The ballot test process has finished.	No action is needed.
1004069 – Selected ballot test finished. {1} ballot stored	The ballot test process has finished and the ballot (s) have been stored.	No action is needed.
1004070 – Vote for test performed: vote for one	The vote for test has been performed.	No action is needed.
1004071 – Vote for test performed: multivote	The vote for test has been performed.	No action is needed.
1004072 – ballots stored	The ballots have been stored.	No action is needed.

System Messages

Error	Cause	Solution
1004073 – Paper low	The amount of paper in the DS200 is running low.	No action is needed.
1004074 – Battery Low Signal Received	The battery is low.	If possible, plug the scanner into a power outlet. The battery may need to be charged for about seven hours.
1004075 – Unit Initialized	The scanner has successfully been initialized.	No action is needed.
1004076 – Blank Ballot. No selections made	A blank ballot has been detected.	Verify the ballot.
1004096 - Poll reopened	The scanner has successfully reopened polls.	No action is needed.
1004102 - Correctly voted	The scanner shows the contest is correctly voted.	No action is needed.
1004103 - Cross Voted Contests	The scanner shows cross voted contests.	Notify appropriate election official.
1004104 - Over Voted Contests	The scanner shows undervoted contests.	Notify appropriate election official.
1004105 - Under Voted Contests	The scanner shows undervoted contests.	Notify appropriate election official.
1004106 - Ballot Data Store	The scanner has successfully stored ballot data.	No action is needed.
1004107 - Ballot Images Stored	The scanner has successfully stored ballot images.	No action is needed.
1004108 - Battery level requires shutdown soon	The scanner's battery is below 25 percent and the scanner is about to shut down.	Notify your poll worker or election official. If you are able to, plug the scanner into an AC power outlet.

System Messages

Error	Cause	Solution
1004109 - Voter Accepted Undervote	The scanner has accepted an undervoted ballot.	No action is needed.
1004110 - Voter Rejected Undervote	The scanner has rejected an undervoted ballot.	The voter must make corrections to the ballot and reinsert the ballot into the scanner.
1004111 – Voter Accepted Overvote	The scanner has accepted an overvoted ballot.	No action is needed
1004112 – Voter Rejected Overvote	The scanner has rejected an overvoted ballot.	The voter will need to contact a poll worker.
1004113 - Voter Accepted Blank Ballot	The scanner has accepted a blank ballot.	No action is needed.
1004114 - Voter Rejected Blank Ballot	The scanner has rejected a blank ballot.	The voter must make corrections to the blank ballot and reinsert the ballot into the scanner.
1004115 - Vote Session Started	The scanner has initiated a voting session.	No action is needed.
1004116 – Voter Accepted Crossover Vote	The scanner has accepted a ballot with crossover votes.	The voter must make their ballot corrections and reinsert the ballot into the scanner.
1004117 – Voter Rejected Crossover Vote	The scanner has rejected a ballot with crossover votes.	The voter must make their ballot corrections and reinsert the ballot into the scanner.
1004118 – Automatically rejected Undervote	A contest has been undervoted and the scanner has been programmed to automatically reject undervoted ballots.	The voter must make their ballot corrections and reinsert the ballot into the scanner.

System Messages

Error	Cause	Solution
1004119 – Automatically rejected Overvote	A contest has been overvoted and the scanner has been programmed to automatically reject overvoted ballots.	The voter must make their ballot corrections and reinsert the ballot into the scanner.
1004120 – Automatically rejected Blank Ballot	A ballot does not contain any votes and the scanner has been programmed to automatically reject blank ballots.	The voter must make their ballot corrections and reinsert the ballot into the scanner.
1004121 – Automatically rejected Crossover Vote	A contest has a crossover vote and the scanner has been programmed to automatically reject crossover votes.	The voter must make their ballot corrections and reinsert the ballot into the scanner.
1004122 – Automatically rejected Unreadable mark	A contest has marks the scanner cannot read and the scanner has been programmed to automatically reject ballots with unreadable marks.	The voter must make their ballot corrections and reinsert the ballot into the scanner.
1004123 – Voter selected language {0}	A ballot language has been selected on the scanner.	No action is needed.
1004124 – Discarded date time changes	The scanner has discarded date and time changes.	No action is needed.
1004125 – Entered Administration Menus	The user has accessed the Administration Menu on the scanner.	No action is needed.
1004126 – Entered Ballot Diagnostics Menu	The user has accessed the Ballot Diagnostic Menu on the scanner.	No action is needed.

System Messages

Error	Cause	Solution
1004127 – Entered Ballot Scan Menu	The user has accessed the Ballot Diagnostic Menu on the scanner.	No action is needed.
1004128 – Completed Printing {0}	The scanner has completed printing a report.	No action is needed.
1004129 – Diverter initialized	The diverter has been initialized.	No action is needed.
1004130 – Entered Hardware Diagnostics Menu	The user has accessed the Hardware Diagnostics Menu on the scanner.	No action is needed.
1004131 – Entered Hardware Reports Menu	The user has accessed the Hardware Reports Menu on the scanner.	No action is needed.
1004132 – Starting ballot diagnostic scan for {0} times	Ballot diagnostic scan is starting.	No action is needed.
1004133 – Stopped ballot diagnostic scan for {0} times	Ballot diagnostic scan is stopped.	No action is needed.
1004133 – Stopped ballot diagnostic scan for {0} times	Ballot diagnostic scan is stopped.	No action is needed.
1004134 – Completed ballot diagnostic scan for {0} times.	Ballot diagnostic scan is completed.	No action is needed.
1004135 – User canceled ballot diagnostic scan at {0} times.	The user has canceled the ballot diagnostic scan.	No action is needed.
1004137 – Exiting Administration Status	The user has exited the administrative functions on the scanner.	No action is needed.
1004138 – Exiting Administration Menus	The user has exited the Administration Menu on the scanner.	No action is needed.
1004139 – Password authenticated	The user's password has been authenticated.	No action is needed.

System Messages

Error	Cause	Solution
1004140 – Ballot Inserted	A ballot has been inserted into the scanner.	No action is needed.
1004141 – Entered Administration Status	The user has accessed the administrative functions of the scanner.	No action is needed.
1004142 – Previewed {0}	A preview of a report appears on the DS200.	No action is needed.
1004143 – Printing {1} copie(s) of {0}	The scanner is printing multiple copies of the same report.	No action is needed.
1004144 – Entered Date Time Options Menu	The user has accessed the Date Time Options Menu.	No action is needed.
1004145– Completed Scanner Calibration Successfully	The scanner has been successfully calibrated.	No action is needed.
1004146 – Initiated Scanner Calibration	The user has initiated the scanner calibration process.	No action is needed.
1004147 – Voter Rejected Unreadable Marks	The scanner has returned a ballot with unreadable marks to the voter.	The voter must make corrections to the ballot and rescan the ballot.
1004148 – User Canceled Printing {0}	The user has pressed the Cancel Printing button.	No action is needed.
1004149 – Attempting to Open Poll	The scanner is attempting to open polls.	No action is needed.
1004150 – Attempting to Close Poll	The scanner is attempting to close polls.	No action is needed.
1004151 – Attempting to Re-Open Poll	The scanner is attempting to reopen polls.	No action is needed.

System Messages

Error	Cause	Solution
1004152 – Attempting to enter Voting Mode	The scanner is attempting to enter voting mode.	No action is needed.
1004153 – Attempting to Enter Administration Menus	The scanner is attempting to enter the Administration Menu.	No action is needed.
1004154 – User canceled Poll Close	The user has chosen not to close polls, possibly by pressing the Don't Close - Keep Voting button.	No action is needed.
1004155 – User canceled security code entry	The user pressed Cancel in the Security Code Entry screen.	No action is needed.
1004156 – Invalid security code entered	An incorrect security code was entered.	Reenter the security code.
1004157 – User Canceled Re-Open Poll	The user has chosen to cancel the Re-Open Poll process, possibly by pressing Finished-Turn Off .	No action is needed.
1004158 – User Confirmed Clear Votes	The user has entered a security code, authorizing the scanner to clear votes on the scanner.	No action is needed.
1004159 – User paused printing	The user has paused printing.	No action is needed.
1004160 – User resumed printing	The user has resumed printing.	No action is needed.
1004161 – Ballot diverted	The ballot has been diverted.	No action is needed.
1004162 – Ballot Stamped	The ballot has been diverted.	No action is needed.
1004164 – User cancelled automatic shutdown.	The user has cancelled the automatic shutdown process.	No action is needed.

System Messages

Error	Cause	Solution
1004163 – Lid Closed. Waiting for automatic shutdown.	The DS200 is in the process of automatically shutting down.	No action is needed.
1004165 – Selected language not supported on scanned ballot. Defaulting to {0}	The language the user selected is not supported on the scanned ballot.	No action is needed.
1004175 – PRECINCT_LABEL activated is {0}	The scanner has logged the activated precinct.	No action is needed.
1004176 – Unable to Replace Precinct Labels	The scanner cannot replace the precinct labels from the election definition.	Contact ES&S for technical support.
1004200 – Power has switched to AC	The scanner has switched from AC to battery power.	No action is needed.
1004201 – Power has switched to DC	The scanner has switched from AC to battery power.	No action is needed.
1004202 – Started on AC	The scanner started up using battery power.	No action is needed.
1004203 – Started on DC	The scanner started up using AC power	No action is needed.
3003001 – Init Failed.	An error occurred while inserting the ballot.	Reinsert the ballot. If the error continues, give the voter a new ballot or contact ES&S technical support.
3003002 – Error scanning ballot.	An error occurred while scanning the ballot.	Reinsert the ballot. If the error continues, give the voter a new ballot or contact ES&S technical support.
3003003 – Error detecting ballot.	An error occurred while inserting the ballot.	Reinsert the ballot. If the error continues, give the voter a new ballot or contact ES&S technical support.

System Messages

Error	Cause	Solution
3003004 – Unable to eject ballot.	The ballot was tabulated, but it did not go into the ballot bin.	Open the ballot box door and clear any jammed ballots. If no ballot jams are detected, open the DS200 read head and advance the counted ballot into the ballot box.
3003005 – Unable to detect ballot diverter.	The DS200 was unable to detect the ballot diverter.	Check the diverter connection on the back of the scanner and press Retry .
3003006 – Unable to get ballot ID.	The scanner could not read the ballot ID.	Reinsert the ballot. If the error continues, give the voter a new ballot or contact ES&S technical support.
3003007 – Unable to get mark on ballot.	A marking error occurred while the scanner scanned the ballot.	Reinsert the ballot. If the error continues, give the voter a new ballot or contact ES&S technical support.
3003008 – Unable to set target type.	A targeting error occurred while the scanner scanned the ballot.	Reinsert the ballot. If the error continues, give the voter a new ballot or contact ES&S technical support.
3003009 – Unable to set ballot size.	The scanner was unable to set the ballot size for the ballot.	Reinsert the ballot. If the error continues, give the voter a new ballot or contact ES&S technical support.
3003010 – Unable to save ballot images.	The scanner was unable to save the images that are on the ballot.	Contact ES&S technical support.
3003011 – Unable to set pixel threshold.	The scanner was unable to set the pixel threshold	Contact ES&S technical support.

System Messages

Error	Cause	Solution
3003012 – Unable to generate report.	The scanner was unable to generate a report.	Contact ES&S technical support.
3003013 – Unable to update Firmware	The scanner was unable to update the firmware.	Contact ES&S technical support.
3003014 – Unable to calibrate Scanner.	The scanner was unable to calibrate.	Contact ES&S technical support.
3003016 – Invalid ballot artwork specified.	The scanner detects invalid ballot artwork.	Contact ES&S technical support.
3003301 – Ballot Couldn't Be Read; Please remove your ballot and re-insert the opposite end first..	The scanner cannot recognize an image on the top of the scanner.	Reinsert the ballot or contact the poll worker or election official.
3003302 – Ballot Couldn't Be Read; Please remove your ballot and re-insert the opposite end first.	The scanner cannot recognize an image on the bottom of the scanner.	Reinsert the ballot or contact the poll worker or election official.
3003303 – Ballot Couldn't Be Read; Please remove your ballot and re-insert the opposite end first.	The scanner cannot recognize an image on the top of the ballot.	Reinsert the ballot or contact the poll worker or election official.
3003304 – Ballot Couldn't Be Read; Please remove your ballot and re-insert the opposite end first.	The scanner cannot recognize an image on the bottom of the ballot.	Reinsert the ballot or contact the poll worker or election official.
3003305 – Ballot Couldn't Be Read; Please remove your ballot and re-insert the opposite end first.	The scanner detected an invalid sequence type.	Reinsert the ballot or contact the poll worker or election official.
3003306 – Ballot Couldn't Be Read; Please remove your ballot and re-insert the opposite end first.	The scanner has detected a marking location error on the ballot.	Reinsert the ballot or contact the poll worker or election official.
3003307 – Ballot Couldn't Be Read; Please remove your ballot and re-insert the opposite end first.	The scanner has detected a marking location error on the ballot.	Reinsert the ballot or contact the poll worker or election official.
3003308 – Ballot Couldn't Be Read; Please remove your ballot and re-insert the opposite end first.	The scanner has detected a marking extraction error on the ballot.	Reinsert the ballot or contact the poll worker or election official.

System Messages

Error	Cause	Solution
3003309 – Ballot Couldn't Be Read; Please remove your ballot and re-insert the opposite end first.	The scanner has detected a marking extraction error on the ballot.	Reinsert the ballot or contact the poll worker or election official.
3003310 – Ballot Couldn't Be Read; Please remove your ballot and re-insert the opposite end first.	The scanner has detected a marking extraction error on the ballot.	Reinsert the ballot or contact the poll worker or election official.
3003311 – Ballot Couldn't Be Read; Please remove your ballot and re-insert the opposite end first.	The scanner has detected a marking recognition error on the ballot.	Reinsert the ballot or contact the poll worker or election official.
3003312 – Ballot Couldn't Be Read; Please remove your ballot and re-insert the opposite end first.	The scanner has detected a marking recognition error on the ballot.	Reinsert the ballot or contact the poll worker or election official.
3003313 – Ballot Couldn't Be Read; Please remove your ballot and re-insert the opposite end first.	The scanner has detected a marking recognition error on the ballot.	Reinsert the ballot or contact the poll worker or election official.
3003314 – Ballot Couldn't Be Read; Please remove your ballot and re-insert the opposite end first.	The scanner has detected a marking recognition error on the ballot.	Reinsert the ballot or contact the poll worker or election official.
3003315 – Ballot Couldn't Be Read; Please remove your ballot and re-insert the opposite end first.	The scanner has detected a marking recognition error on the ballot.	Reinsert the ballot or contact the poll worker or election official.
3003316 – Ballot Couldn't Be Read; Please remove your ballot and re-insert the opposite end first.	The scanner has detected a marking recognition error on the ballot.	Reinsert the ballot or contact the poll worker or election official.
3003317 – Ballot Couldn't Be Read; Please remove your ballot and re-insert the opposite end first.	The scanner has detected a marking recognition error on the ballot.	Reinsert the ballot or contact the poll worker or election official.

System Messages

Error	Cause	Solution
3003318 – Ballot Couldn't Be Read; Please remove your ballot and re-insert the opposite end first.	The scanner could not determine the ballot orientation.	Reinsert the ballot. If the error continues, give the voter a new ballot or contact ES&S technical support.
3003319 – Ballot Couldn't Be Read; Please remove your ballot and re-insert the opposite end first.	The scanner detected an invalid skew in the front-left timing track.	Reinsert the ballot. If the error continues, give the voter a new ballot or contact ES&S technical support.
3003320 – Ballot Couldn't Be Read; Please remove your ballot and re-insert the opposite end first.	The scanner detected an invalid skew in the front-right timing track.	Reinsert the ballot. If the error continues, give the voter a new ballot or contact ES&S technical support.
3003321 – Ballot Couldn't Be Read; Please remove your ballot and re-insert the opposite end first.	The scanner detected an invalid skew in the front-top timing track.	Reinsert the ballot. If the error continues, give the voter a new ballot or contact ES&S technical support.
3003322 – Ballot Couldn't Be Read; Please remove your ballot and re-insert the opposite end first.	The scanner detected an invalid skew in the front-bottom timing track.	Reinsert the ballot. If the error continues, give the voter a new ballot or contact ES&S technical support.
3003323 – Ballot Couldn't Be Read; Please remove your ballot and re-insert the opposite end first.	The scanner detected an invalid skew in the back-left timing track.	Reinsert the ballot. If the error continues, give the voter a new ballot or contact ES&S technical support.
3003324 – Ballot Couldn't Be Read; Please remove your ballot and re-insert the opposite end first.	The scanner detected an invalid skew in the back-right timing track.	Reinsert the ballot. If the error continues, give the voter a new ballot or contact ES&S technical support.

System Messages

Error	Cause	Solution
3003325 – Ballot Couldn't Be Read; Please remove your ballot and re-insert the opposite end first.	The scanner detected an invalid skew in the back-top timing track.	Reinsert the ballot. If the error continues, give the voter a new ballot or contact ES&S technical support.
3003326 – Ballot Couldn't Be Read; Please remove your ballot and re-insert the opposite end first.	The scanner detected an invalid skew in the back-bottom timing track.	Reinsert the ballot. If the error continues, give the voter a new ballot or contact ES&S technical support.
3003327 – Ballot Couldn't Be Read; Please remove your ballot and re-insert the opposite end first.	The front-left timing track is not detected.	Reinsert the ballot. If the error continues, give the voter a new ballot or contact ES&S technical support.
3003328 – Ballot Couldn't Be Read; Please remove your ballot and re-insert the opposite end first.	The front-right timing track is not detected.	Reinsert the ballot. If the error continues, give the voter a new ballot or contact ES&S technical support.
3003329 – Ballot Couldn't Be Read; Please remove your ballot and re-insert the opposite end first.	The front-top timing track is not detected.	Reinsert the ballot. If the error continues, give the voter a new ballot or contact ES&S technical support.
3003330 – Ballot Couldn't Be Read; Please remove your ballot and re-insert the opposite end first.	The front-bottom timing track is not detected.	Reinsert the ballot. If the error continues, give the voter a new ballot or contact ES&S technical support.
3003331 – Ballot Couldn't Be Read; Please remove your ballot and re-insert the opposite end first.	The back-left timing track is not detected.	Reinsert the ballot. If the error continues, give the voter a new ballot or contact ES&S technical support.

System Messages

Error	Cause	Solution
3003332 – Ballot Couldn't Be Read; Please remove your ballot and re-insert the opposite end first.	The back-right timing track is not detected.	Reinsert the ballot. If the error continues, give the voter a new ballot or contact ES&S technical support.
3003333 – Ballot Couldn't Be Read; Please remove your ballot and re-insert the opposite end first.	The back-top timing track is not detected.	Reinsert the ballot. If the error continues, give the voter a new ballot or contact ES&S technical support.
3003334 – Ballot Couldn't Be Read; Please remove your ballot and re-insert the opposite end first.	The back-bottom timing track is not detected.	Reinsert the ballot. If the error continues, give the voter a new ballot or contact ES&S technical support.
3003335– Ballot Couldn't Be Read; Please remove your ballot and re-insert the opposite end first.	The front-left timing track failed validation.	Reinsert the ballot. If the error continues, give the voter a new ballot or contact ES&S technical support.
3003336– Ballot Couldn't Be Read; Please remove your ballot and re-insert the opposite end first.	The front-right timing track failed validation.	Reinsert the ballot. If the error continues, give the voter a new ballot or contact ES&S technical support.
3003337– Ballot Couldn't Be Read; Please remove your ballot and re-insert the opposite end first.	The front-top timing track failed validation.	Reinsert the ballot. If the error continues, give the voter a new ballot or contact ES&S technical support.
3003338 – Ballot Couldn't Be Read; Please remove your ballot and re-insert the opposite end first.	The front-bottom timing track failed validation.	Reinsert the ballot. If the error continues, give the voter a new ballot or contact ES&S technical support.

System Messages

Error	Cause	Solution
3003339– Ballot Couldn't Be Read; Please remove your ballot and re-insert the opposite end first.	The back-left timing track failed validation.	Reinsert the ballot. If the error continues, give the voter a new ballot or contact ES&S technical support.
3003340 – Ballot Couldn't Be Read; Please remove your ballot and re-insert the opposite end first.	The back-right timing track failed validation.	Reinsert the ballot. If the error continues, give the voter a new ballot or contact ES&S technical support.
3003341– Ballot Couldn't Be Read; Please remove your ballot and re-insert the opposite end first.	The back-top timing track failed validation.	Reinsert the ballot. If the error continues, give the voter a new ballot or contact ES&S technical support.
3003342– Ballot Couldn't Be Read; Please remove your ballot and re-insert the opposite end first..	The back-bottom timing track failed validation.	Reinsert the ballot. If the error continues, give the voter a new ballot or contact ES&S technical support.
3003343 – Ballot Couldn't Be Read; Please remove your ballot and re-insert the opposite end first.	A system error occurred in the front-left timing track.	Reinsert the ballot. If the error continues, give the voter a new ballot or contact ES&S technical support.
3003344 – Ballot Couldn't Be Read; Please remove your ballot and re-insert the opposite end first.	A system error occurred in the front-right timing track.	Reinsert the ballot. If the error continues, give the voter a new ballot or contact ES&S technical support.
3003345 – Ballot Couldn't Be Read; Please remove your ballot and re-insert the opposite end first.	A system error occurred in the front-top timing track.	Reinsert the ballot. If the error continues, give the voter a new ballot or contact ES&S technical support.

System Messages

Error	Cause	Solution
3003346 – Ballot Couldn't Be Read; Please remove your ballot and re-insert the opposite end first.	A system error occurred in the front-bottom timing track.	Reinsert the ballot. If the error continues, give the voter a new ballot or contact ES&S technical support.
3003347 – Ballot Couldn't Be Read; Please remove your ballot and re-insert the opposite end first.	A system error occurred in the back-left timing track.	Reinsert the ballot. If the error continues, give the voter a new ballot or contact ES&S technical support.
3003348 – Ballot Couldn't Be Read; Please remove your ballot and re-insert the opposite end first.	A system error occurred in the back-right timing track.	Reinsert the ballot. If the error continues, give the voter a new ballot or contact ES&S technical support.
3003349 – Ballot Couldn't Be Read; Please remove your ballot and re-insert the opposite end first.	A system error occurred in the back-top timing track.	Reinsert the ballot. If the error continues, give the voter a new ballot or contact ES&S technical support.
3003350 – Ballot Couldn't Be Read; Please remove your ballot and re-insert the opposite end first.	A system error occurred in the back-bottom timing track.	Reinsert the ballot. If the error continues, give the voter a new ballot or contact ES&S technical support.
3003351 – Ballot Couldn't Be Read; Please remove your ballot and re-insert the opposite end first.	A system error occurred in the front-left code channel.	Reinsert the ballot. If the error continues, give the voter a new ballot or contact ES&S technical support.
3003352 – Ballot Couldn't Be Read; Please remove your ballot and re-insert the opposite end first.	A system error occurred in the front-right code channel.	Reinsert the ballot. If the error continues, give the voter a new ballot or contact ES&S technical support.

System Messages

Error	Cause	Solution
3003353 – Ballot Couldn't Be Read; Please remove your ballot and re-insert the opposite end first.	A system error occurred in the back-left code channel.	Reinsert the ballot. If the error continues, give the voter a new ballot or contact ES&S technical support.
3003354 – Ballot Couldn't Be Read; Please remove your ballot and re-insert the opposite end first.	A system error occurred in the back-right code channel.	Reinsert the ballot. If the error continues, give the voter a new ballot or contact ES&S technical support.
3003355 – Ballot Couldn't Be Read; Please remove your ballot and re-insert the opposite end first.	The system could not extract the front-left timing track.	Reinsert the ballot. If the error continues, give the voter a new ballot or contact ES&S technical support.
3003356 – Ballot Couldn't Be Read; Please remove your ballot and re-insert the opposite end first.	The system could not extract the front-right timing track.	Reinsert the ballot. If the error continues, give the voter a new ballot or contact ES&S technical support.
3003357 – Ballot Couldn't Be Read; Please remove your ballot and re-insert the opposite end first.	The system could not extract the front-top timing track.	Reinsert the ballot. If the error continues, give the voter a new ballot or contact ES&S technical support.
3003358 – Ballot Couldn't Be Read; Please remove your ballot and re-insert the opposite end first.	The system could not extract the front-bottom timing track.	Reinsert the ballot. If the error continues, give the voter a new ballot or contact ES&S technical support.
3003359 – Ballot Couldn't Be Read; Please remove your ballot and re-insert the opposite end first.	The system could not extract the back-left timing track.	Reinsert the ballot. If the error continues, give the voter a new ballot or contact ES&S technical support.

System Messages

Error	Cause	Solution
3003360 – Ballot Couldn't Be Read; Please remove your ballot and re-insert the opposite end first.	The system could not extract the back-right timing track.	Reinsert the ballot. If the error continues, give the voter a new ballot or contact ES&S technical support.
3003361 – Ballot Couldn't Be Read; Please remove your ballot and re-insert the opposite end first.	The system could not extract the back-top timing track.	Reinsert the ballot. If the error continues, give the voter a new ballot or contact ES&S technical support.
3003362 – Ballot Couldn't Be Read; Please remove your ballot and re-insert the opposite end first.	The system could not extract the back-bottom timing track.	Reinsert the ballot. If the error continues, give the voter a new ballot or contact ES&S technical support.
3003363 – Ballot Couldn't Be Read; Please remove your ballot and re-insert the opposite end first.	The system could not extract the front-left code channel.	Reinsert the ballot. If the error continues, give the voter a new ballot or contact ES&S technical support.
3003364 – Ballot Couldn't Be Read; Please remove your ballot and re-insert the opposite end first.	The system could not extract the front-right code channel.	Reinsert the ballot. If the error continues, give the voter a new ballot or contact ES&S technical support.
3003365 – Ballot Couldn't Be Read; Please remove your ballot and re-insert the opposite end first.	The system could not extract the back-left code channel.	Reinsert the ballot. If the error continues, give the voter a new ballot or contact ES&S technical support.
3003366 – Ballot Couldn't Be Read; Please remove ballot, press OK, and re-insert.	The system could not extract the back-right code channel.	Reinsert the ballot. If the error continues, give the voter a new ballot or contact ES&S technical support.

System Messages

Error	Cause	Solution
3003367 – Ballot Couldn't Be Read; Please remove your ballot and re-insert the opposite end first.	The system could not recognize the ballot.	Reinsert the ballot. If the error continues, give the voter a new ballot or contact ES&S technical support.
3003368 – Unprocessed ballot element. Ballot cannot be scanned.	The system could not scan the ballot due to an unprocessed ballot element.	Reinsert the ballot. If the error continues, give the voter a new ballot or contact ES&S technical support.
3004015 – Paper processor ready.	The paper processor is enabled.	No action is needed.
3013001 – Ballot was removed during scanning. Please press OK, and re-insert.	The ballot was inserted far enough to be scanned, but it was removed before it fell into the ballot bin.	Open the ballot bin and check for jams.
3013002 – Ballot was not inserted far enough. Please remove ballots, press OK, and re-insert.	The ballot was not inserted far enough to be scanned, but it was removed before it reached the ballot rollers.	Reinsert the ballot into the scanner.
3013003 – Ballot jam: Please remove Ballot, press OK, and re-insert.	The ballot is stuck in the scanner.	The ballot could be damaged. Straighten the ballot and rescan it. If jamming continues, give the voter a new ballot and open the read head to check for obstructions in the feed path.

System Messages

Error	Cause	Solution
3013004 – Ballot jam: Stacked diverter.	Ballots may be jammed in the ballot box.	Pull the DS200 forward and retrieve the ballot. Check the ballot box for any jams. If you attempt to clear the jam, the ballot could fall into the ballot bin and make it difficult to find if the ballot requires rescanning.
3013005 – Multiple ballots detected. Please remove ballots, press OK, and insert only one ballot at a time.	The voter attempted to scan two or more ballots simultaneously.	Rescan the ballots, one ballot at a time.
3013006 – System Error.	A scanner driver error has occurred.	Contact ES&S for technical support.
3013007 – Ballot Jam: Check the ballot bin or diverter.	The ballot jammed while the scanner was scanning it.	Check the ballot box door. Make sure the ballot bin door is open to allow passage into the box. Rescan the ballot.
3013008 – Ballot too long. Please remove ballot and press OK.	The ballot is longer than specified. An incorrect ballot may have been inserted into the DS200.	Contact a poll worker. If the ballot is correct, contact ES&S for technical support.
3013011 – Error scanning ballot.	The scanner has detected a USB error.	Contact ES&S for technical support.
3013012 – Error scanning ballot.	The scanner has detected a USB write error.	Contact ES&S for technical support.
3013013 – Error scanning ballot.	The scanner has detected a USB read error.	Contact ES&S for technical support.
3013014 – Error scanning ballot.	The scanner has detected a file open error.	Contact ES&S for technical support.

System Messages

Error	Cause	Solution
3013015 – Error scanning ballot.	The scanner has detected a file write error.	Contact ES&S for technical support.
3013016 – Error scanning ballot.	The scanner has detected a file read error.	Contact ES&S for technical support.
3013017 – Error scanning ballot.	The scanner has detected a file status error.	Contact ES&S for technical support.
3013018 – Error scanning ballot.	The scanner has detected a null input pointer	Contact ES&S for technical support.
3013019 – Error scanning ballot.	The scanner has detected a system error.	Contact ES&S for technical support.
3013020– Error scanning ballot.	The scanner has detected a motor timeout error.	Contact ES&S for technical support.
3013021 – Error scanning ballot.	A scanner ID error has occurred.	Contact ES&S for technical support.
3013022 – Error scanning ballot.	An invalid speed error has occurred.	Contact ES&S for technical support.
3013023 – Error scanning ballot.	The scanner cannot set the ballot speed.	Contact ES&S for technical support.
3013024 – Error scanning ballot.	The scanner has detected a bad LED value.	Contact ES&S for technical support.
3013025 – Error scanning ballot.	The scanner cannot set its LED value.	Contact ES&S for technical support.
3013026 – Error scanning ballot.	A bad motor step error has occurred.	Contact ES&S for technical support.
3013027 – Error scanning ballot.	The scanner cannot set its threshold level.	Contact ES&S for technical support.
3013028 – Error scanning ballot.	The scanner has detected a bad LED state.	Contact ES&S for technical support.

System Messages

Error	Cause	Solution
3013029 – Error scanning ballot.	The scanner cannot set its counterfeit values.	Contact ES&S for technical support.
3013030 – Error scanning ballot.	The scanner has detected a bad counterfeit state.	Contact ES&S for technical support.
3013031 – Error scanning ballot.	The scanner cannot set its multiplier.	Contact ES&S for technical support.
3013032 – Error scanning ballot.	The scanner has detected a bad power mode.	Contact ES&S for technical support.
3013033 – Error scanning ballot.	The ballot image was too large to scan.	Contact ES&S for technical support.
3013034 – Error scanning ballot.	The dark level calibration is outside the valid range.	Contact ES&S for technical support.
3013035 – Error scanning ballot.	The dark level calibration adjustment has exceeded the retry limit.	Contact ES&S for technical support.
3013036 – Error scanning ballot.	The dark level calibration adjustment is too high.	Contact ES&S for technical support.
3013037 – Error scanning ballot.	The dark level calibration adjustment is too low.	Contact ES&S for technical support.
3013038 – Error scanning ballot.	The white level calibration has exceeded the retry limit.	Contact ES&S for technical support.
3013039 – Error scanning ballot.	The white level calibration adjustment is too low.	Contact ES&S for technical support.
3013040 – Error scanning ballot.	A time out error occurred while the scanner was waiting for ballot image data.	Contact ES&S for technical support.

System Messages

Error	Cause	Solution
3013041 – Error scanning ballot.	A time out error occurred while the scanner was reading ballot image data.	Contact ES&S for technical support.
3013042 – Error scanning ballot.	An error occurred while the scanner was being reset.	Contact ES&S for technical support.
3013043 – Error scanning ballot.	An invalid document length was requested.	Contact ES&S for technical support.
3013044 – Error scanning ballot.	An invalid document length was requested.	Contact ES&S for technical support.
3023001 – No ballot has been scanned.	The ballot failed to scan.	Contact ES&S for technical support.
3023002 – System Error - Contact Election Official.	There is a system-related error.	Contact an election official.
3023003 – System Error - Contact Election Official.	There is a system-related error.	Contact an election official.
3023004 – System Error - Contact Election Official.	There is a system-related error.	Contact an election official.
5011001 – Memory Allocation Failed.	A memory-related error has occurred.	Contact ES&S for technical support.
5011002 – Parser creation Failed.	The parser failed to be created.	Contact ES&S for technical support.
5011003 – Cannot open Messages.xml file.	An XML error has occurred.	Contact ES&S for technical support.
5011004 – Parse error in Messages.xml file.	An XML error has occurred.	Contact ES&S for technical support.
5104072 - PPP service started Bug# is unknown		Contact ES&S for technical support.
5103073 - PPP service could not be started for telephone number {0}</entry>		Contact ES&S for technical support.
5104074 - SFTP service started for IP address {0}.</entry>		Contact ES&S for technical support.

System Messages

Error	Cause	Solution
5103075 - SFTP service could not be started: {0}.		Contact ES&S for technical support.
5104076 - SFTP transfer complete for file {0}.		Contact ES&S for technical support.
5103077 - SFTP transfer for file {0} failed: error {1}.		Contact ES&S for technical support.
5103078 - SFTP service request failed: error {0}.		Contact ES&S for technical support.
5104079 - SFTP service canceled.		Contact ES&S for technical support.
5114001 - Dial Up Connection Established		Contact ES&S for technical support.
5113002 - Dial Error: Fatal Error While Dialing		Contact ES&S for technical support.
5113003 - Dial Error: Invalid Dial Options		Contact ES&S for technical support.
5113004 - Dial Error: Invalid Permissions For Dialing		Contact ES&S for technical support.
5113005 - Dial Error: Kernel Does Not Support Dialing		Contact ES&S for technical support.
5113006 - Dial Error: Dialing Terminated By Signal		Contact ES&S for technical support.
5113007 - Dial Error: Serial Port Lock Fail		Contact ES&S for technical support.
5113008 - Dial Error: Serial Port Open Fail		Contact ES&S for technical support.
5113009 - Dial Error: Connect Script Failed		Contact ES&S for technical support.
5113010 - Dial Error: Pty Command Failed		Contact ES&S for technical support.
5113011 - Dial Error: Negotiation Failed		Contact ES&S for technical support.

System Messages

Error	Cause	Solution
5113012 - Dial Error: Peer Authorization Failed</entry>		Contact ES&S for technical support.
5113013 - Dial Error: Idle Link Terminated</entry>		Contact ES&S for technical support.
5113014 - Dial Error: Connect Timed Out</entry>		Contact ES&S for technical support.
5113015 - Dial Error: Incoming Call</entry>		Contact ES&S for technical support.
5113016 - Dial Error: Peer Not Responding</entry>		Contact ES&S for technical support.
5113017 - Dial Error: Modem Hang up</entry>		Contact ES&S for technical support.
5113018 - Dial Error: Loop Back Detected</entry>		Contact ES&S for technical support.
5113019 - Dial Error: Init Script Failed</entry>		Contact ES&S for technical support.
5113020 - Dial Error: Authentication To Peer Failed</entry>		Contact ES&S for technical support.
5113021 - Dialing Setup Failure.</entry>		Contact ES&S for technical support.
5113022 - Dialing Setup Failure.</entry>		Contact ES&S for technical support.
5113023 - Dialing Setup Failure.</entry>		Contact ES&S for technical support.
5113024 - Dialing Setup Failure.</entry>		Contact ES&S for technical support.
5113025 - Dialing Setup Failure.</entry>		Contact ES&S for technical support.
5113026 - Dialing Setup Failure.</entry>		Contact ES&S for technical support.
5113027 - Dialing Setup Failure.</entry>		Contact ES&S for technical support.

System Messages

Error	Cause	Solution
5123001 - SFTP Error: Login Failed</entry>		Contact ES&S for technical support.
5123002 - SFTP Error: Login Failed</entry>		Contact ES&S for technical support.
5123003 - SFTP Error: Login Failed</entry>		Contact ES&S for technical support.
5123004 - SFTP Error: Login Failed</entry>		Contact ES&S for technical support.
5123005 - SFTP Error: Login Failed</entry>		Contact ES&S for technical support.
5123006 - SFTP Error: Transfer Failed</entry>		Contact ES&S for technical support.
5123007 - SFTP Error: Transfer Failed</entry>		Contact ES&S for technical support.
5123008 - SFTP Error: Transfer Failed</entry>		Contact ES&S for technical support.
5123009 - SFTP Error: Transfer Failed</entry>		Contact ES&S for technical support.
5123010 - SFTP Error: Transfer Failed</entry>		Contact ES&S for technical support.
5123011 - SFTP Error: Transfer Failed</entry>		Contact ES&S for technical support.
5123012 - SFTP Error: Transfer Failed</entry>		Contact ES&S for technical support.
5123013 - SFTP Error: Transfer Failed</entry>		Contact ES&S for technical support.
5123014 - SFTP Error: Transfer Failed</entry>		Contact ES&S for technical support.
5123015 - SFTP Error: Transfer Failed</entry>		Contact ES&S for technical support.
5123016 - SFTP Error: Transfer Failed</entry>		Contact ES&S for technical support.

System Messages

Error	Cause	Solution
5123017 - SFTP Error: Login Failed</entry>		Contact ES&S for technical support.
5123018 - SFTP Error: Failure During Upload</entry>		Contact ES&S for technical support.
5123019 - SFTP Error: Failure During Upload</entry>		Contact ES&S for technical support.
5123020 - SFTP Error: Failure During Upload</entry>		Contact ES&S for technical support.
5123021 - SFTP Error: Password Rejected By Host</entry>		Contact ES&S for technical support.
5123022 - SFTP Error: Connection Refused By Host</entry>		Contact ES&S for technical support.
6001001 – Presentation read pipe failed.	An error occurred while starting the scanner.	Contact ES&S for technical support
6001002 – Improper input parameter.	An error occurred while starting the scanner.	Contact ES&S for technical support.
6001003 – Colon missing after command.	An error occurred while starting the scanner.	Contact ES&S for technical support.
6001004 – Command word too long.	An error occurred while starting the scanner.	Contact ES&S for technical support.
6001005 – Unknown command word:{1}	An error occurred while starting the scanner.	Contact ES&S for technical support.
6001006 – Newline missing in command.	An error occurred while starting the scanner.	Contact ES&S for technical support.
6001007 – Command number too long.	An error occurred while starting the scanner.	Contact ES&S for technical support.
6001008 – Command number missing.	An error occurred while starting the scanner.	Contact ES&S for technical support.
6001009 – Corrupt command number.	An error occurred while starting the scanner.	Contact ES&S for technical support.
6001010 – Command number too big.	An error occurred while starting the scanner.	Contact ES&S for technical support.

System Messages

Error	Cause	Solution
6001011 – Comand number too small.	An error occurred while starting the scanner.	Contact ES&S for technical support.
6001012 – Config file open failed.	An error occurred while starting the scanner.	Contact ES&S for technical support.
6001013 – Config file read failed.	An error occurred while starting the scanner.	Contact ES&S for technical support.
6001014 – Config file write failed.	An error occurred while starting the scanner.	Contact ES&S for technical support.
6001015 – Memory allocation failed.	An error occurred while starting the scanner.	Contact ES&S for technical support.
6001016 – Presentation write pipe failed.	An error occurred while starting the scanner.	Contact ES&S for technical support.
6001018 – No string following command.	An error occurred while starting the scanner.	Contact ES&S for technical support.
6001019 – Unknown password type.	An error occurred while starting the scanner.	Contact ES&S for technical support.
6001023 – Business startup failed.	An error occurred while starting the scanner.	Contact ES&S for technical support.
6001024 – Config file closed failed.	An error occurred while starting the scanner.	Contact ES&S for technical support.
6001026 – Could not create image directory.	An error occurred while starting the scanner.	Contact ES&S for technical support.
6001028 – Cannot open partition file.	An error occurred while starting the scanner.	Contact ES&S for technical support.
6001029 – Cannot read partition file.	An error occurred while starting the scanner.	Contact ES&S for technical support.
6001033 – Cannot un-mount ESS memory device.	An error occurred while starting the scanner.	Contact ES&S for technical support.
6001052 – Time string too long.	The system has detected an invalid time string error.	Contact ES&S for technical support.
6001053 – Time string invalid.	The system has detected an invalid time string error.	Contact ES&S for technical support.

System Messages

Error	Cause	Solution
6001054 – Clock set failed.	The system has detected an invalid clock setting error.	Contact ES&S for technical support.
6001056 – Invalid service request.	The system has detected an invalid service request error.	Contact ES&S for technical support.
6001057 – Invalid set-audio value.	The system has detected an invalid audio value error.	Contact ES&S for technical support.
6001058 – Invalid DST value.	The system has detected an invalid DST value error.	Contact ES&S for technical support.
6001060 – Improper conditions for test.	The system has detected an improper conditions for test error.	Contact ES&S for technical support.
6001077 – Cannot unlink localtime file.	The system could not unlink its local time file.	Contact ES&S for technical support.
6001078 – Cannot re-link localtime file.	The system could not relink its local time file.	Contact ES&S for technical support.
6001092 – Unable to initialize redundant storage.	An error occurred while starting the scanner.	Contact ES&S for technical support.
6001096 – Error getting current time.	The system could not retrieve the current time.	Contact ES&S for technical support.
6001100 – Power device string invalid.	The system could not read the power device string.	Contact ES&S for technical support.
6001101 – HAL PRINTER communication failed.	The system can not communicate with the printer.	Contact ES&S for technical support.
6001103 – Invalid device state.	The system is in an invalid state.	Contact ES&S for technical support.
6001114 – Hardware copy timeout.	The system is experiencing a hardware copy timeout.	Contact ES&S for technical support.

System Messages

Error	Cause	Solution
6001122 – Backup Memory Device present but not initialized	The backup memory device is inserted, but needs to be initialized.	Contact ES&S for technical support.
6001123 – Not enough free space on Backup Memory Device	The backup memory device's memory is full.	Contact ES&S for technical support.
6001124 – Backup Memory Device erase failed	The backup memory device could not be erased.	Contact ES&S for technical support.
6001125 – Backup Memory Device initialization failed	The system could not initialize the backup memory device.	Contact ES&S for technical support.
6001126 – Backup Memory Device validation failed	The system could not validate the backup memory device	Verify that the backup memory device is inserted. Contact ES&S for additional technical support.
6001127 – Copy to Backup Memory Device failed	The system could not copy to the backup memory device	Verify that the backup memory device is inserted and retry. Contact ES&S for additional technical support.
6002017 – WriteIn name too long.	The system could not read the Write-in name.	Contact ES&S for technical support.
6003030 – Cannot mount ESS memory device.	A USB error occurred during the open polls process.	Contact ES&S for technical support.
6003031 – Cannot copy data from ESS Memory Device.	A USB error occurred during the open polls process.	Contact ES&S for technical support.
6003032 – Cannot copy header from ESS Memory Device.	An error occurred during the open polls process.	Contact ES&S for technical support.
6003034 – HAL communication failed.	An error occurred during the open polls process.	Contact ES&S for technical support.

System Messages

Error	Cause	Solution
6003035 – No ESS Memory Device. Cannot load data.	The scanner could not detect a USB device.	Open the access panel and check to see if a USB device is inserted into the scanner. If the USB device is inserted into the scanner, contact ES&S for technical support.
6003036 – Cannot find clear header file.	An error occurred during the open polls process.	Contact ES&S for technical support.
6003037 – Cannot close clear header file.	An error occurred during the open polls process.	Contact ES&S for technical support.
6003038 – Unknown ESS Memory Device type in header file.	An error occurred during the open polls process.	Contact ES&S for technical support.
6003039 – Cannot copy ESS Memory Device type from header file.	An error occurred during the open polls process.	Contact ES&S for technical support.
6003040 – Invalid size string in clear header.	An error occurred during the open polls process.	Contact ES&S for technical support.
6003042 – Cannot load. Terminal not cleared.	An error occurred during the open polls process.	Contact ES&S for technical support.
6003043 – Cannot open. Data not loaded.	An error occurred during the open polls process.	Contact ES&S for technical support.
6003044 – Cannot close. Election not open.	An error occurred during the close polls process.	Contact ES&S for technical support.
6003045 – Cannot collect. Election not closed.	An error occurred during the close polls process.	Check to see if you correctly closed the election. If you have correctly closed the election, contact ES&S for technical support.
6003046 – Cannot clear election. Votes not collected.	An error occurred during the close polls process.	Check to see if you correctly closed the election. If you have correctly closed the election, contact ES&S for technical support.

System Messages

Error	Cause	Solution
6003047 – Cannot clear votes. Votes not collected.	An error occurred during the close polls process.	Check to see if you correctly closed the election. If you have correctly closed the election, contact ES&S for technical support.
6003050 – Cannot clear election. Terminal is open.	An error occurred during the close polls process.	Check to see if you correctly closed the election. If you have correctly closed the election, contact ES&S for technical support.
6003051 – Cannot clear election. Votes on machine.	An error occurred during the close polls process.	Check to see if you correctly closed the election. If you have correctly closed the election, contact ES&S for technical support.
6003063 – Cannot move data package.	An error occurred during the close polls process.	Contact ES&S for technical support.
6003065 – Cannot open. L&A votes present.	An error occurred during the close polls process.	Contact ES&S for technical support.
6003066 – Cannot open. Regular votes present.	An error occurred during the close polls process.	Contact ES&S for technical support.
6003068 – Cannot clear ESS Memory Device	The DS200 cannot clear the ES&S memory device.	Contact ES&S for technical support.
6003070 – Cannot copy results bundle to ESS Memory Device.	A USB error occurred during the close polls process.	Contact ES&S for technical support.
6003071 – Cannot copy SPP bundle to ESS Memory Device.	A USB error occurred during the close polls process.	Contact ES&S for technical support.
6003073 – Invalid LED ID.	An invalid LED error occurred during the close poll process.	Contact ES&S for technical support.

System Messages

Error	Cause	Solution
6003074 – Cannot copy election bundle to ESS Memory Device.	A USB error occurred during the close polls process.	Contact ES&S for technical support.
6003076 – Could not write to clear header file.	An error occurred during the close poll process.	Contact ES&S for technical support.
6003079 – DST information missing.	An error occurred during the close polls process.	Contact ES&S for technical support.
6003080 – Cannot get election data from ESS Memory Device.	An error occurred during the close polls process.	Contact ES&S for technical support.
6003081 – Cannot parse ESS Memory Device election data.	This error is primarily due to corrupted poll data on the media device. This may be due to corrupted data copied to the media device or a faulty media device.	Recreate the poll data for this tabulator using a different media device. If this error re-occurs with a different media device, contact ES&S technical support.
6003085 – HAL LED communication failed.	An error occurred while starting the scanner.	Contact ES&S for technical support.
6003086 – HAL communication failed.	An error occurred while starting the scanner.	Contact ES&S for technical support.
6003087 – Cannot copy recovery file to ESS Memory Device.	An error occurred while starting the scanner.	Contact ES&S for technical support.
6003088 – Cannot clear header file on ESS Memory Device.	An error occurred while starting the scanner.	Contact ES&S for technical support.
6003089 – Firmware Version Open Failed	An error occurred while starting the scanner.	Contact ES&S for technical support.
6003090 – Firmware version read failed.	An error occurred while starting the scanner.	Contact ES&S for technical support.
6003091 – Firmware version close failed.	An error occurred while starting the scanner.	Contact ES&S for technical support.
6003093 – Unable to open typevotes.txt file.	An error occurred while starting the scanner.	Contact ES&S for technical support.
6003094 – HAL BUZZER communication failed.	A ballot scanning error has occurred.	Contact ES&S for technical support.

System Messages

Error	Cause	Solution
6003095– No valid Poll Worker Panel found.	A ballot scanning error has occurred.	Contact ES&S for technical support.
6003098– Copy config.dat file to cf_b failed.	An error occurred while starting the scanner.	Contact ES&S for technical support.
6003099– Copy config.dat file to cf_c failed.	An error occurred while starting the scanner.	Contact ES&S for technical support.
6003102 – No valid power management board found.	The scanner could not locate a valid power management board.	Contact ES&S for technical support.
6003104 – HAL Backlight communication failed.	An error occurred while starting the scanner.	Contact ES&S for technical support.
6003105 – Not enough space in the application disk drive.	An error occurred while starting the scanner.	Contact ES&S for technical support.
6003106 – Not enough space in backup disk 1 device.	An error occurred while starting the scanner.	Contact ES&S for technical support.
6003107 – Not enough space in backup disk 2 device.	An error occurred while starting the scanner.	Contact ES&S for technical support.
6003108 – HAL failed to read device name list.	An error occurred while starting the scanner.	Contact ES&S for technical support.
6003109 – Unable to close typevotes.txt file.	An error occurred while starting the scanner.	Contact ES&S for technical support.
6003110 – Unable to open ESS Memory Device mount directory.	An error occurred while starting the scanner.	Contact ES&S for technical support.
6003111 – ESS Memory Device contains REGVOTES and LAVOTES.	An error occurred while starting the scanner.	Contact ES&S for technical support.
6003112 – ESS Memory Device contains LAVOTES and OPEN.	An error occurred while starting the scanner.	Contact ES&S for technical support.+
6003113 – Cannot clear ESS Memory Device mount directory. REGVOTES present.	An error occurred while starting the scanner.	Contact ES&S for technical support.
6003115 – Ballot image comparison failed:	An error occurred while starting the scanner.	Contact ES&S for technical support.
6003116 – Ballot image processing failed:	An error occurred while starting the scanner.	Contact ES&S for technical support.

System Messages

Error	Cause	Solution
6003117 – Configuration file mismatch. This unit cannot be used for voting until the error has been corrected.	There is a configuration file mismatch.	Contact ES&S for technical support.
6003119 – No ballot storage space available.	The scanner has run out of ballot storage space.	Contact ES&S for technical support.
6003120 – System command execution failed: {1} returned {2}	An error occurred while starting the scanner.	Contact ES&S for technical support.
6003128 – Create Validation Media Failed	The validation media could not be created.	Contact ES&S for technical support.
6003129 – Check for Backup Memory Device Type failed.	The check for backup media device type failed.	Contact ES&S for technical support.
6003131 – Unable to save Election Security Code.	The election security code could not be saved.	Contact ES&S for technical support.
6004020 – Business data initialized.	The system has initialized business data.	No action is required.
6004021 – Business process ready.	The scanner's business process is ready.	No action is required.
6004022 – Open process complete.	The open polls process was successfully completed.	No action is required.
6004025 – Close time extended to:	The scanner extended the close time by the specified amount.	No action is required.
6004027 – Election files loaded.	The scanner has successfully loaded the election files.	No action is required.
6004041 – Close process complete.	The close polls process was successfully completed.	No action is required.
6004048 – Election data cleared.	The election data has been cleared.	No action is required.
6004055 – Clock reset to:	The clock has been reset to the displayed value.	No action is required.

System Messages

Error	Cause	Solution
6004059 – Ballot stored.	The ballot has been stored.	No action is required.
6004061 – Ballot preview started.	The scanner has started the ballot preview process.	No action is required.
6004062 – Ballot preview finished.	The scanner has completed the ballot preview process.	No action is required.
6004064 – Select ballot test started.	The scanner has started the select ballot test.	No action is required.
6004067 – Select ballot test finished.	The scanner has completed the select ballot test.	No action is required.
6004069 – ESS memory device cleared.	The ESS memory device has been cleared.	No action is required.
6004072 – Collection process complete.	Votes were successfully collected after the polls closed.	No action is required.
6004075 – Recollection process complete.	The recollection process successfully collected after the polls closed.	No action is required.
6004082 – Vote for test started.	The vote for test process has started.	No action is required.
6004083 – Vote for test finished	The vote for test process has completed.	No action is required.
6004075 – Vote for test finished.	The vote for test process has completed.	No action is required.
6004097 – DST setting:	This is the setting for the date and time display.	No action is required.
6004118 – LS running firmware version:	This is the setting for firmware version.	No action is required.
6004121 – Keys detected on poll media: {0}	This is the keys on the poll media.	No action is required.

System Messages

Error	Cause	Solution
6004130 – Election Security Code persisted.	There is an error related to the election security code.	Contact ES&S for support.
7001001 – Improper input parameter.	The scanner has detected an invalid input parameter.	Contact ES&S for technical support.
7001011 – Ballot image allocation failed.	An XML error occurred.	Contact ES&S for technical support.
7001015 – Memory allocation failed.	An memory allocation error has occurred.	Contact ES&S for technical support.
7001016 – Ballot ID party ID mismatch.	There is a mismatch between the ballot ID and the party ID.	Contact ES&S for technical support.
7001020 – Invalid choice ID.	The choice ID is invalid.	Contact ES&S for technical support.
7001027 – Invalid report type.	The scanner has detected an invalid report type.	Contact ES&S for technical support.
7001028 – Could not open write-in file.	The scanner could not open the write-in file.	Contact ES&S for technical support.
7001029 – Could not write to write-in file.	The scanner could not write to the write-in file.	Contact ES&S for technical support.
7001030 – Could not open image (ILS) file.	The scanner could not open the image (ILS) file.	Contact ES&S for technical support.
7001031 – Could not write to image (ILS) file.	The scanner could not write to the image (ILS) file.	Contact ES&S for technical support.
7001033 – Could not open event (ELS) file.	The scanner could not open event (ELS) file.	Contact ES&S for technical support.
7001034 – Could not write to event (ELS) file.	The scanner could not write to event (ELS) file.	Contact ES&S for technical support.
7001035 – Could not open audit log file.	The scanner cannot open the audit log file.	Contact ES&S for technical support.

System Messages

Error	Cause	Solution
7001036 – Illegal event (ELS) file format.	There is a file format error.	Contact ES&S for technical support.
7001037 – Error with scratch directory.	There is a scratch directory error.	Contact ES&S for technical support.
7001038 – Error with unzipping files in scratch dir.	There is an error when unzipping files in the scratch directory.	Contact ES&S for technical support.
7001040 – Error opening timestamp .ts file.	The DS200 cannot open the timestamp .ts file.	Contact ES&S for technical support.
7001041 – Problem with data in timestamp .ts file.	There is a problem with the timestamp .ts file.	Contact ES&S for technical support.
7001165 – Ballot processing failed.	There is a ballot processing error.	Contact ES&S for technical support.
7003002 – Candidate data missing.	An error occurred during the open polls process.	Contact ES&S for technical support.
7003003 – Contest data missing.	An error occurred during the open polls process.	Contact ES&S for technical support.
7003004 – Election data missing.	An error occurred during the open polls process.	Contact ES&S for technical support.
7003005 – PollPlace data missing.	An error occurred during the open polls process.	Contact ES&S for technical support.
7003006 – Election District data missing.	An error occurred during the open polls process.	Contact ES&S for technical support.
7003007 – Invalid election district ID	The scanner detected an invalid election district ID.	Contact ES&S for technical support.
7003008 – Ballot data missing.	The scanner is missing ballot data.	Contact ES&S for technical support.
7003009 – Invalid ballot ID	The scanner an invalid ballot ID.	Contact ES&S for technical support.
7003010 – Ballot style data missing.	The scanner is missing ballot style data.	Contact ES&S for technical support.
7003012 – Ballot image data missing.	The scanner is missing ballot image data.	Contact ES&S for technical support.

System Messages

Error	Cause	Solution
7003013 – Business data missing.	An error occurred during the open polls process.	Contact ES&S for technical support.
7003014 – Ballot data not loaded.	Ballot data has not been loaded onto the scanner.	Contact ES&S for technical support.
7003016 – Ballot ID party ID mismatch - contact poll worker	The scanner detected a party mismatch for the ballot ID.	Contact ES&S for technical support.
7003017 – Could not store ballot.	An XML error has occurred.	Contact ES&S for technical support.
7003018 – Could not clear votes.	The scanner could not clear votes during the reopen polls process.	Contact ES&S for technical support.
7003019 – Could not clear election.	The scanner could not clear the election during the reopen polls process.	Contact ES&S for technical support
7003020 – Invalid Choice ID. - contact poll worker	The scanner has detected an invalid choice ID.	Contact ES&S for technical support.
7003021 – Data file decompression failed.	The data file decompression process	Contact ES&S for technical support.
7003025 – Could not open report file.	The scanner could not open the report file.	Contact ES&S for technical support.
7003022 – Directory opening failed.	The directory could not be opened.	Contact ES&S for technical support.
7003023 – Could not read from LPP file.	The system could not read from the LPP file.	Contact ES&S for technical support.
7003024 – Could not open LPP file.	The LPP file could not be opened.	Contact ES&S for technical support.
7003025 – Could not open report file.	The system could not open the report file.	Contact ES&S for technical support.
7003026 – Could not write to report file.	The system could not write to the report file.	Contact ES&S for technical support.
700302 – Could not write to report file.	The system could not write to the report file.	Contact ES&S for technical support.

System Messages

Error	Cause	Solution
7003032 – Could not open terminal - votes exist.	The scanner can not be opened because of existing votes.	Contact ES&S for technical support
7003039 – There was a problem accessing the ESS Memory Device. If the ESS Memory Device has been removed, please re-insert the ESS Memory Device and try again.	The scanner cannot access the USB memory drive.	Open the access panel and check to see if the USB flash drive is properly inserted in the DS200. Contact ES&S for technical support.
7003042 – Error copying file to ESS Memory Device.	A USB error has occurred.	Open the access panel and check to see if the USB flash drive is properly inserted in the DS200. Contact ES&S for technical support.
7003043 – Warning: File not replaced on ESS Memory Device.	A USB error has occurred.	Open the access panel and check to see if the USB flash drive is properly inserted in the DS200. Contact ES&S for technical support.
7003044 – Error creating Recovery ESS Memory Device header file.	A USB error has occurred.	Open the access panel and check to see if the USB flash drive is properly inserted in the DS200. Contact ES&S for technical support.
7003045 – Error copying Recovery header file to ESS Memory Device.	A USB error has occurred.	Open the access panel and check to see if the USB flash drive is properly inserted in the DS200. Contact ES&S for technical support.
7003046 – Unable to load election to redundant storage.	The scanner cannot load the election to redundant storage.	Contact ES&S for technical support.

System Messages

Error	Cause	Solution
7003047 – Error computing MD5 checksum.	The scanner cannot compute the MD5 checksum.	Contact ES&S for technical support.
7003048 – MD5 checksum compare failed.	The MD5 checksum comparison failed.	Contact ES&S for technical support.
7003049 – Cannot open input file for copy.	The scanner cannot open the input file.	Contact ES&S for technical support.
7003050 – Cannot open output file for copy.	The scanner cannot open the output file.	Contact ES&S for technical support.
7003051 – Cannot copy file {1}	The scanner cannot copy a file.	Contact ES&S for technical support.
7003052 – Cannot close input file after copy.	The scanner cannot close the input file.	Contact ES&S for technical support.
7003053 – Cannot close output file after copy.	The scanner cannot close the output file.	Contact ES&S for technical support.
7003054 – Error creating election recovery zip file.	There was an error when creating the election recovery zip file.	Contact ES&S for technical support.
7003055 – Error creating *. EBA archive file.	There was an error when creating the *. EBA archive file.	Contact ES&S for technical support.
7003056 – Error creating *. ERB results bundle.	There was an error when creating the *. ERB results bundle.	Contact ES&S for technical support.
7003057 – Error creating *. LPB results bundle.	There was an error when creating the *. LPB results bundle.	Contact ES&S for technical support.
7003058 – ESS Memory Device election does not match terminal election. Report not available.	The election on the USB memory stick does not match the terminal election.	Contact ES&S for technical support.
7003059 – No election loaded. Report not available.	There is no election loaded.	Contact ES&S for technical support.

System Messages

Error	Cause	Solution
7003060 – Redundant image data stores A and B do not match. Use LRecover to collect votes from this terminal.	The redundant image data stores A and B do not match.	Contact ES&S for technical support.
7003061 – Redundant image data stores B and C do not match. Use LRecover to collect votes from this terminal.	The redundant image data stores B and C do not match.	Contact ES&S for technical support.
7003062 – Redundant image data stores A and C do not match. Use LRecover to collect votes from this terminal.	The redundant image data stores A and C do not match.	Contact ES&S for technical support.
7003063 – Unable to store results to redundant storage.	The scanner cannot store results to redundant storage.	Contact ES&S for technical support.
7003065 – Voting session data not loaded.	The voting session data is not loaded.	Contact ES&S for technical support.
7003066 – Invalid signature for file {1}.	The scanner has detected an invalid signature file.	Contact ES&S for technical support.
7003067 – Unable to clear file {1}.	The scanner was unable to clear a file.	Contact ES&S for technical support.
7003068 – Unable to generate security key pair	The scanner was unable to generate a security key.	Contact ES&S for technical support.
7003165 – Ballot processing failed.	An error occurred during the close polls process.	Contact ES&S for technical support.
7003999 – Error in file {1}: line number (2)	The scanner has detected a system error.	Contact ES&S for technical support.
7004064 – Ballot difference detected.	The scanner has detected a system error.	Contact ES&S for technical support.
7101001 - Invalid signature for file	The scanner has detected an invalid signature file.	Contact ES&S for technical support.

System Messages

Error	Cause	Solution
7101002 – Unable to clear file {1}	The scanner is unable to clear a file.	Contact ES&S for technical support.
7101003 – Unable to generate security key pair.	The scanner is unable to generate a security key pair.	Contact ES&S for technical support.
7101004 – Clear operation requested using improper ESS Memory Device.	A USB error has occurred.	Contact ES&S for technical support.
7101005 – Unable to write clear data to {1}.	The DS200 has detected a system error.	Contact ES&S for technical support.
7101006 – Unable to decrypt file {1}.	The DS200 has detected a system error.	Contact ES&S for technical support.
7101007 – Invalid authentication.	The DS200 has detected a system error.	Contact ES&S for technical support.
7101008 – Unable to write decrypted File {1}.	The DS200 has detected a system error.	Contact ES&S for technical support.
7101009 – Unable to write encrypted file {1}.	The DS200 has detected a system error.	Contact ES&S for technical support.
7101010 – Unable to encrypt file {1}.	The DS200 has detected a system error.	Contact ES&S for technical support.
7101011 – Unable to sign file. Key not valid.	The DS200 has detected a system error.	Contact ES&S for technical support.
7101012 – EQC data invalid or missing.	The DS200 has detected a system error.	Contact ES&S for technical support.
7101013 – Authentication data invalid or missing.	The DS200 has detected a system error.	Contact ES&S for technical support.
7101014 – Security digest operation failed.	The DS200 has detected a system error.	Contact ES&S for technical support.
8001002 –XML parser memory allocation failed	An XML error occurred during the open polls process.	Contact ES&S for technical support.
8001003 –Cannot create XML parser object	An XML error occurred during the open polls process.	Contact ES&S for technical support.

System Messages

Error	Cause	Solution
8001004 –Ballot Image XML file open failed	An XML error occurred during the open polls process.	Contact ES&S for technical support.
8003001 – Parse error in Ballot Image XML	An error occurred during the close polls process.	Contact ES&S for technical support.
8003005 – Ballot IMG file open failed	An error occurred during the close polls process.	Contact ES&S for technical support.
8003006 – Invalid Undervote contest ID in Ballot Image XML	An XML error has occurred during the close polls process.	Contact ES&S for technical support.
8003007 – Invalid Undervote count in Ballot Image XML	An XML error has occurred during the close polls process.	Contact ES&S for technical support.
8003008 – Duplicate Undervote contest ID in Ballot Image XML	An XML error has occurred during the close polls process.	Contact ES&S for technical support.
8003009 – Invalid Overvote contest ID in Ballot Image XML	An XML error has occurred during the close polls process.	Contact ES&S for technical support.
8003010 – Invalid Overvote count in Ballot Image XML	An XML error has occurred during the close polls process.	Contact ES&S for technical support.
8003011 – Duplicate Overvote contest ID in Ballot Image XML	An XML error has occurred during the close polls process.	Contact ES&S for technical support.
8003012 – Invalid Choice ID in Ballot Image XML	An XML error has occurred during the close polls process.	Contact ES&S for technical support.
8003013 – Invalid Choice attribute in Ballot Image XML	An XML error has occurred during the close polls process.	Contact ES&S for technical support.
8003014 – Invalid WriteIn candidate in Ballot Image XML	An XML error has occurred during the close polls process.	Contact ES&S for technical support.

System Messages

Error	Cause	Solution
8003015 – Duplicate WriteIn candidate in Ballot Image XML	An XML error has occurred during the close polls process.	Contact ES&S for technical support.
8003016 – WriteIn Text Too Large in Ballot Image XML	An XML error has occurred during the close polls process.	Contact ES&S for technical support.
8003017 – No data for election district ID in ballot IMG	Ballot image is missing data.	Contact ES&S for technical support.
8003018 – Invalid election district ID in ballot IMG	Ballot image is missing data.	Contact ES&S for technical support.
8003019 – No data for machine serial number in ballot IMG	Ballot image is missing data.	Contact ES&S for technical support.
8003020 – No data for ballot style ID in ballot IMG	Ballot image is missing data.	Contact ES&S for technical support.
8003021 – No data for party counter in ballot IMG	Ballot image is missing data.	Contact ES&S for technical support.
8003022 – Invalid party counter in ballot IMG	Ballot image is missing data.	Contact ES&S for technical support.
8003023 – No data for counter count in ballot IMG	Ballot image is missing data.	Contact ES&S for technical support.
8003024 – No data for next counter in ballot IMG	Ballot image is missing data.	Contact ES&S for technical support.
8003025 – Invalid vote counter in ballot IMG	Ballot image has invalid data.	Contact ES&S for technical support.
8003026 – Invalid candidate counter in ballot IMG	Ballot image has invalid data.	Contact ES&S for technical support.
8003027 – Overvoted contest in ballot IMG	Ballot image has invalid data.	Contact ES&S for technical support.
8003028 – Duplicate votes in ballot IMG	Ballot image has invalid data.	Contact ES&S for technical support.
8003029 – Parse error in Business.XML	An XML error has occurred during the open polls process.	Contact ES&S for technical support.

System Messages

Error	Cause	Solution
8003030 – Unable to open Business .XML File	An XML error has occurred during the open polls process.	Contact ES&S for technical support.
8003031 – Multiple CandList Elements in Business	An XML error has occurred during the open polls process.	Contact ES&S for technical support.
8003032 – Multiple BStyleList Elements in Business	An error occurred during the open polls process.	Contact ES&S for technical support.
8003033 – No parent return function for Cand	An error occurred during the open polls process.	Contact ES&S for technical support.
8003034 – No Contest list supplied to Cand	An error occurred during the open polls process.	Contact ES&S for technical support.
8003035 – Multiple name attributes for Cand	An error occurred during the open polls process.	Contact ES&S for technical support.
8003036 – Owinging Cont for Cand not found	An error occurred during the open polls process.	Contact ES&S for technical support.
8003037 – Owinging Cont out of range for Cand	An error occurred during the open polls process.	Contact ES&S for technical support.
8003038 – Parse error in Cand	An error occurred during the open polls process.	Contact ES&S for technical support.
8003039 – Invalid PtyRef attribute(s) in Cand	An error occurred during the open polls process.	Contact ES&S for technical support.
8003040 – No parent return function for Cont	An error occurred during the open polls process.	Contact ES&S for technical support.
8003041 – Multiple Party references for Cont	An error occurred during the open polls process.	Contact ES&S for technical support.
8003042 – No Cont List for Cont reference in Cont	An error occurred during the open polls process.	Contact ES&S for technical support.
8003043 – Multiple Cont references for Cont	An error occurred during the open polls process.	Contact ES&S for technical support.
8003044 – Cont reference for Cont not found	An error occurred during the open polls process.	Contact ES&S for technical support.
8003045 – Multiple name attributes for Cont	An error occurred during the open polls process.	Contact ES&S for technical support.

System Messages

Error	Cause	Solution
8003047 – Parse error in Cont	An error occurred during the open polls process.	Contact ES&S for technical support.
8003048 – No Pparent return function for ElecOpts	An error occurred during the open polls process.	Contact ES&S for technical support.
8003049 – Found NULL tag name in ElecOpts	An error occurred during the open polls process.	Contact ES&S for technical support.
8003050 – No parent return function for Elec security codes	An error occurred during the open polls process.	Contact ES&S for technical support.
8003051 – Parse error in Election Security Codes	An error occurred during the open polls process.	Contact ES&S for technical support.
8003052 – Parse error in Election.XML	An .XML error occurred during the open polls process.	Contact ES&S for technical support.
8003053 – Unable to open Election.XML File	An .XML error occurred during the open polls process.	Contact ES&S for technical support.
8003054 – No parent return function for PollOpts	An error occurred during the open polls process.	Contact ES&S for technical support.
8003055 – Found NULL tag name in PollOpts	An error occurred during the open polls process.	Contact ES&S for technical support.
8003056 – No BStyle array provided to PollPlace	An error occurred during the open polls process.	Contact ES&S for technical support.
8003057 – Parse error in PollPlace.XML	An .XML error occurred during the open polls process.	Contact ES&S for technical support.
8003058 – Unable to open PollPlace.XML file	An .XML error occurred during the open polls process.	Contact ES&S for technical support.
8003059 – No SBusiness or SPollPlace provided to PollPlaceResults	An error occurred during the close polls process.	Contact ES&S for technical support.
8003060 – Parse error in PollPlaceResults.XML	An .XML error occurred during the close polls process.	Contact ES&S for technical support.

System Messages

Error	Cause	Solution
8003061 – Unable to open PollPlaceResults.XML	An .XML error occurred during the close polls process.	Contact ES&S for technical support.
8003062 – Wrong Poll Place ID in PollPlaceResults	An error occurred during the close polls process.	Contact ES&S for technical support.
8003063 – Election District results invalid for PollPlaceResults	An error occurred during the close polls process.	Contact ES&S for technical support.
8003064 – Duplicate election district results in PollPlaceResults	An error occurred during the close polls process.	Contact ES&S for technical support.
8003065 – No parent return function for Prec	An error occurred during the open polls process.	Contact ES&S for technical support.
8003066 – No BStyle list supplied to Prec	An error occurred during the open polls process.	Contact ES&S for technical support.
8003067 – Multiple name attributes for Prec	An error occurred during the open polls process.	Contact ES&S for technical support.
8003068 – Invalid Parser Error	An error occurred during the open polls process.	Contact ES&S for technical support.
8003069 – Invalid BStyleref attribute (s) in Prec	An error occurred during the open polls process.	Contact ES&S for technical support.
8003070 – Found NULL tag name in Prec	An error occurred during the open polls process.	Contact ES&S for technical support.
8003071 – AddBStyleToList(NULL) in Prec	An error occurred during the open polls process.	Contact ES&S for technical support.
8003072 – Referenced BStyle does not exist in Prec	An error occurred during the open polls process.	Contact ES&S for technical support.
8003073 – BStyleRef out of bounds in Prec	An error occurred during the open polls process.	Contact ES&S for technical support.
8003074 – No parent return function for PrecResults	An error occurred during the open polls process.	Contact ES&S for technical support.
8003075 – Error: no SBusiness object supplied to PrecResults	An error occurred during the open polls process.	Contact ES&S for technical support.
8003076 – Found NULL tag name in PrecResults	An error occurred during the open polls process.	Contact ES&S for technical support.

System Messages

Error	Cause	Solution
8003077 – No parent return function for Version	An error occurred during the open polls process.	Contact ES&S for technical support.
8003078 – Found NULL tag name in Version	An error occurred during the open polls process.	Contact ES&S for technical support.
8003079 – No parent return function for BStyle	An error occurred during the open polls process.	Contact ES&S for technical support.
8003080 – No Cont list supplied to BStyle	An error occurred during the open polls process.	Contact ES&S for technical support.
8003081 –Unknown parser error	An error occurred during the open polls process.	Contact ES&S for technical support.
8003082 – Multiple Party references for BStyle	An error occurred during the open polls process.	Contact ES&S for technical support.
8003083 – Found NULL tag name in BStyle	An error occurred during the open polls process.	Contact ES&S for technical support.
8003084 – Invalid ContRef attributes in BStyle	An error occurred during the open polls process.	Contact ES&S for technical support.
8003085 – AddContToList(NULL) in BStyle	An error occurred during the open polls process.	Contact ES&S for technical support.
8003086 – ContRef out of bounds in BStyle	An error occurred during the open polls process.	Contact ES&S for technical support.

Chapter 12: Revision History

DS200 Operator's Guide v. 2.7 Document Version 10.1 February 7, 2013

Chapter	Description	Project
Chapter 4: Pre-Election Day Tasks	Updated Recommended Supplies list to include seals Updated screen shots and text in Seals and Locks section Updated text in Steel Ballot Box section Added to remove seal if needed to Install the Backup Memory Device section	
Chapter 6: Post Election Day Tasks	Added screen shots showing where to add seals to the Closing and Removing the DS200 Tote Bin from the Plastic Ballot Box section	
Chapter 8: Scanner Maintenance	Added steps about seals to the Replace the Paper Roll section.	

DS200 Operator's Guide v. 2.7 Document Version 9.1 January 30, 2013

Chapter	Description	Project
Chapter 3: Introduction to the DS200	Added Note to Election Definition section	
Chapter 4: Pre-Election Day Tasks	Added Note to Ballot Diagnostics section.	
Chapter 5: Election Day Tasks	Updated DS200 supported languages in Multi-Language Voting section.	

DS200 Operator's Guide v. 2.7 Document Version 8.1 January 16, 2013

Chapter	Description	Project
Chapter 1: Overview	Updated bullets in Power Source and Backup Battery section	
Chapter 4: Pre-Election Day Tasks	Added Blank USB to Optional Step: Create Media to Validate Firmware	

DS200 Operator's Guide v. 2.7
Document Version 8.1
January 16, 2013

Chapter	Description	Project
Chapter 5: Election Day Tasks	Removed "and hold" from Step 3 in Close the Polls section Updated list of reports in Print Election Reports	

DS200 Operator's Guide v. 2.7
Document Version 7.1
January 9, 2013

Chapter	Description	Project
Chapter 4: Pre-Election Day Tasks	Updated screen shot in DS200 Carrying Case and Ballot Bin Security Seals section.	

DS200 Operator's Guide v. 2.7
Document Version 6.1
December 17, 2012

Chapter	Description	Project
Chapter 4: Pre-Election Day Tasks	Updated Load the Election Definition section.	

DS200 Operator's Guide v. 2.7
Document Version 5.1
August 24, 2012

Chapter	Description	Project
All	General updated for usability	

DS200 Operator's Guide v. 2.7
Document Version 5.0
August 17, 2012

Chapter	Description	Project
Chapter 5: Election Day Tasks	Removed Section to transfer results by modem.	

DS200 Operator's Guide v. 2.7
Document Version 4.0
June 22, 2012

Chapter	Description	Project
Chapter 4: Pre-Election Day Tasks	Updated Optional Step: Create Media to Validate Firmware section.	
Chapter 5: Election Day Tasks	Updated Multi-Language Voting section.	

DS200 Operator's Guide v. 2.7
Document Version 3.0
May 25, 2012

Chapter	Description	Project
All	General updated for usability	
Chapter 5: Election Day Tasks	Added Remove Ballots from the Metal Ballot Box section.	

DS200 Operator's Guide v. 2.7
Document Version 2.0
March 23, 2012

Chapter	Description	Project
All	Removed references for AudioVote.	
Chapter 1: Overview	Added Roles section	
Chapter 4: Pre-Election Day Tasks	Updated Attach the DS200 to the Plastic Ballot Box section, changed ballot bin to ballot box.	
Chapter 7: Reports	Added Note referencing replacing paper when report is printing.	

DS200 Operator's Guide v. 2.7
Document Version 1.0
November 15, 2011

Chapter	Description	Project
All	Initial Document	

Index

A

- Administration Menu, 54
- Administration Mode, 18
- Appendix, 131
 - Troubleshooting, 145
- Assist ADA Voters, 88
- Attach the DS200 to the Ballot Box, 27
 - Assemble the Plastic Ballot Box, 27
 - Attach the DS200 Power Source to the Plastic Ballot Box, 28, 35
 - Attach the DS200 to the Metal Ballot Box, 40

B

- Backup Memory Device, 48, 49
- Ballot Box, 14
 - Attach the DS200, 27, 40
 - Clean Metal Ballot Box, 125
 - Clean Plastic Ballot Box, 124
 - Remove Scanner, 106
- Ballot Diagnostics, 57
 - Reports, 57
 - Scan Ballot, 57
- Ballot Status Accounting Report, 113
- Battery
 - Backup, 12
 - Charge the Battery, 129
 - Check the Battery Charge, 47
 - Maintenance, 128
 - Replacement Warning, 11
- Blank Ballots, 84

C

- Calibrate Scanner, 66
- Calibrate the Touch Screen, 66, 147
- Charge the Battery, 47, 129
- Check the Battery Charge, 47
- Clean the Ballot Box, 124
 - Metal, 125
 - Plastic, 124
- Clean the Scanner, 122
- Cleaning, 10
- Clear the DS200, 49
- Close the Polls, 93, 143
- Configuration Report, 118
- Contact ES&S
 - Ordering Information, 3
 - Support Representative, 3
 - Technical Support, 2

D

- Damage Requiring Service, 11
- Date Settings, 60
- DS200 Post Election Tasks, 111
- DS200 Quick Start Guide, 132
 - Attach the DS200 to the Metal Ballot Box, 134
 - Attach the DS200 to the Plastic Ballot Box, 132
 - Close the Polls, 143
 - DS200 Seals and Locks, 137
 - Open the Polls, 140
- DS200 Reports and Maintenance, 111
 - Reports, 112
 - Scanner Maintenance, 122
- DS200 Seals and Locks, 37, 137

E

- Election Day Tasks, 73
 - Close the Polls, 93
 - Handling Uncounted Ballots, 91
 - Open the Polls, 73
 - Print Election Reports, 104
 - Reopen Polls and Clear Vote Totals, 97
 - Reopen the Polls Without Clearing Vote Totals, 95
 - Transfer Results, 105
 - Voting, 77
 - Write-in Votes, 87
- Election Definition, 19
 - Check for Accuracy, 54
 - Load, 51
- Election Security, 19
- Election Startup Reports, 112
 - Ballot Status Accounting Report, 113
 - Configuration Report, 118
 - Event Log Report, 117
 - Zero Report, 116
- Emergency Procedure to Shutdown the DS200, 95
- Event Log Report, 117

F

- Facilities, Furnishings and Fixtures Required for DS200 Operation, 4

H

- Handling Uncounted Ballots, 91
- Hardware Diagnostics, 58
 - Hardware Reports, 58

Hardware Reports, 58
 Hardware Settings, 65
 Heating, 10

I

Inserting the DS200(i) Tote Bin into the Plastic Ballot Box, 43
 Installing the Backup Memory Device
 USB Backup Memory Device
 Redundant Storage, 48
 Introduction, 1
 Introduction to the DS200, 12
 Overview, 2
 Safety Information, 9
 Introduction to the DS200
 Ballot Box, 14
 Election Definition, 19
 Election Security, 19
 Operating Modes, 18
 Power Source and Backup Battery, 12
 Scanning Ballots, 15

L

Loading New Firmware, 45

M

Menu Display, 17
 Metal Ballot Box, 92
 Metal Ballot Box, Attach the DS200, 134
 Multi-Language Voting, 85

N

Numeric Messages, 154

O

Open the Polls, 73
 Operating Modes, 18
 Administration Mode, 18
 Polls Closed Mode, 19
 Polls Open Mode, 18
 Ordering Information Contact, 3
 Overview, 2
 Contact ES&S for Technical Support, 2
 Facilities, Furnishings and Fixtures Required for DS200 Operation, 4
 General Timeline for Election Preparation, 3

Overvote and Undervote Warnings, 80
 Overvote Warnings, 78

P

Plastic Ballot Box, 92
 Assembly, 27
 Attach the DS200, 132
 Attach the DS200 Power Source, 28, 35
 Poll Closing Report, 119
 Results Report, 120
 Polls Closed Mode, 19
 Polls Open Mode, 18
 Post Election Day Tasks, 106
 Remove the Scanner from the Ballot Box, 106
 Power Cord Protection, 10
 Power Source, 12
 Power Sources, 9
 Pre-Election Day Tasks, 26
 Attach the DS200 to the Ballot Box, 27
 Ballot Diagnostics, 57
 Calibrate the Touch Screen, 66
 Hardware Diagnostics, 58
 Prepare the Counter, 44
 Pre-Voting Checklist, 69
 Recommended Supplies, 26
 System Settings, 60
 Test the Thermal Printer, 68
 Prepare the Counter, 44
 Administration Menu, 54
 Charge the Battery, 47
 Check the Election Definition for Accuracy, 54
 Clear the DS200, 49
 Load the Election Definition, 51
 Pre-Voting Checklist, 69
 Print Election Reports, 104

Q

Quick Start Guide, 132

R

Recommended Supplies, 26
 Recovering or Replacing the DS200, 146
 Remove Ballots from the Metal Ballot Box, 104
 Reopen the Polls and Clear Vote Totals, 97
 Reopen the Polls Without Clearing Vote Totals, 95
 Replace the Paper Roll, 125
 Report Format, 112
 Report Options, 76, 91
 Reports, 57, 112

- Election Startup Reports, 112
 - Format, 112
 - Poll Closing Report, 119
- Results Report, 120
- Roles, 8

S

- Safety Information, 9
 - Important Safety Instructions, 9
 - Warning Symbols, 9
- Safety Instructions, 9
 - Battery Replacement Warning, 11
 - Cleaning, 10
 - Damage Requiring Service, 11
 - Heating, 10
 - Power Cord Protection, 10
 - Power Sources, 9
 - Service, 11
 - Ventilation, 10
 - Water and Moisture, 10
- Scan Ballot, 57
- Scanner Maintenance, 122
 - Clean the Ballot Box, 124
 - Clean the Scanner, 122
 - Maintain the Scanner Battery, 128
 - Replace the Paper Roll, 125
- Scanning Ballots, 15
 - Menu Display, 17
 - Touch Screen Controls, 16
 - USB Flash Drive, 16
- Seals and Locks, 37
- Service, 11
- Setup of the Backup Memory Device
 - USB Backup Memory Device
 - Redundant Storage, 49
- Steel Ballot Box, 39, 139
- Support Representative Contact, 3
- System Error Recovery, 153
- System Messages, 153
- System Settings, 60
 - Change Date and Time Settings, 60

T

- Technical Support Contact, 2
- Thermal Printer Test, 68
- Time Settings, 60
- Timeline for Election Preparation, 3
- Top CIS Threshold & Bottom CIS Threshold, 65
- Touch Screen Controls, 16
- Transfer Results, 105
- Transfer Results by Modem, 95, 105

- Troubleshooting, 145
 - Calibrate the Touch Screen, 147
 - Emergency Ballot Storage Bin, 145

U

- Unclearly Marked Ballots, 82
- Undervote Warnings, 79
- Unreadable Marks, 82
- USB Backup Memory Device
 - Redundant Memory Storage, 48
- USB Flash Drive, 16
- Using the DS200 in an Election, 25
 - Election Day Tasks, 73
 - Post Election Day Tasks, 106
 - Pre-Election Day Tasks, 26

V

- Ventilation, 10
- Verification Messages, 153
- Voting, 77
 - Multi-Language Voting, 85
 - Overvote Warnings, 78
 - Undervote Warnings, 79

W

- Warning Symbols, 9
- Water and Moisture, 10
- Write-in Votes, 87

Z

- Zero Report, 116